

# Cognex MVS-8000 Series

## MVS-8500 Series Hardware Manual

October 2013

The software described in this document is furnished under license, and may be used or copied only in accordance with the terms of such license and with the inclusion of the copyright notice shown on this page. Neither the software, this document, nor any copies thereof may be provided to or otherwise made available to anyone other than the licensee. Title to and ownership of this software remains with Cognex Corporation or its licensor.

Cognex Corporation assumes no responsibility for the use or reliability of its software on equipment that is not supplied by Cognex Corporation. Cognex Corporation makes no warranties, either express or implied, regarding the described software, its merchantability or its fitness for any particular purpose.

The information in this document is subject to change without notice and should not be construed as a commitment by Cognex Corporation. Cognex Corporation is not responsible for any errors that may be present in either this document or the associated software.

Copyright © 2013 Cognex Corporation  
All Rights Reserved  
Printed in U.S.A.

This document may not be copied in whole or in part, nor transferred to any other media or language, without the written permission of Cognex Corporation.

Portions of the hardware and software provided by Cognex may be covered by one or more of the U.S. and foreign patents listed below as well as pending U.S. and foreign patents. Such pending U.S. and foreign patents issued after the date of this document are listed on Cognex web site at <http://www.cognex.com/patents>.

#### **CVL**

5495537, 5548326, 5583954, 5602937, 5640200, 5717785, 5751853, 5768443, 5825483, 5825913, 5850466, 5859923, 5872870, 5901241, 5943441, 5949905, 5978080, 5987172, 5995648, 6002793, 6005978, 6064388, 6067379, 6075881, 6137893, 6141033, 6157732, 6167150, 6215915, 6240208, 6240218, 6324299, 6381366, 6381375, 6408109, 6411734, 6421458, 6457032, 6459820, 6490375, 6516092, 6563324, 6658145, 6687402, 6690842, 6718074, 6748110, 6751361, 6771808, 6798925, 6804416, 6836567, 6850646, 6856698, 6920241, 6959112, 6975764, 6985625, 6993177, 6993192, 7006712, 7016539, 7043081, 7058225, 7065262, 7088862, 7164796, 7190834, 7242801, 7251366, EP0713593, JP3522280, JP3927239

#### **VGR**

5495537, 5602937, 5640200, 5768443, 5825483, 5850466, 5859923, 5949905, 5978080, 5995648, 6002793, 6005978, 6075881, 6137893, 6141033, 6157732, 6167150, 6215915, 6324299, 6381375, 6408109, 6411734, 6421458, 6457032, 6459820, 6490375, 6516092, 6563324, 6658145, 6690842, 6748110, 6751361, 6771808, 6804416, 6836567, 6850646, 6856698, 6959112, 6975764, 6985625, 6993192, 7006712, 7016539, 7043081, 7058225, 7065262, 7088862, 7164796, 7190834, 7242801, 7251366

#### **OMNIVIEW**

6215915, 6381375, 6408109, 6421458, 6457032, 6459820, 6594623, 6804416, 6959112, 7383536

The following are registered trademarks of Cognex Corporation:

|           |                             |           |                  |                |            |
|-----------|-----------------------------|-----------|------------------|----------------|------------|
| acuCoder  | acuFinder                   | acuReader | acuWin           | BGAll          | Checkpoint |
| Cognex    | Cognex, Vision for Industry | CVC-1000  | CVL              | DisplayInspect |            |
| ID Expert | PastelInspect               | PatFind   | PatFlex          | PatInspect     | PatMax     |
| PatQuick  | PixelProbe                  | SMD4      | Virtual Checksum | VisionLinx     | VisionPro  |
| VisionX   |                             |           |                  |                |            |

Other Cognex products, tools, or other trade names may be considered common law trademarks of Cognex Corporation. These trademarks may be marked with a "TM". Other product and company names mentioned herein may be the trademarks of their respective owners.

# Contents

|  |    |
|--|----|
| ■ <b>Preface</b> .....                                   | 7  |
| MVS-8500 Series Naming Convention .....                  | 8  |
| Compatibility Notes .....                                | 8  |
| Software Compatibility .....                             | 9  |
| Hardware Compatibility .....                             | 9  |
| Internal Drive RGB Color Cameras .....                   | 11 |
| Board Ordering .....                                     | 11 |
| Style Conventions Used in This Manual .....              | 16 |
| Text Style Conventions .....                             | 16 |
| Microsoft Windows Support .....                          | 16 |
| Cognex Offices .....                                     | 17 |
| ■ <b>Chapter 1: MVS-8500 Series Installation</b> .....   | 19 |
| Host PC Requirements .....                               | 20 |
| Installing the MVS-8500 Series .....                     | 21 |
| MVS-8500/8510: Selecting a PCI Slot .....                | 21 |
| Identifying a 66 MHz PCI Slot .....                      | 21 |
| PCI-X Slots .....  | 22 |
| MVS-8500e/8510e: Selecting a PCI Express Slot .....      | 23 |
| Installation Steps .....                                 | 23 |
| Configuring Cameras .....                                | 27 |
| Configuring JAI CV-A1 Cameras .....                      | 27 |
| Configuring JAI CV-A2 Cameras .....                      | 28 |
| Configuring Sony DXC-390 Color Cameras .....             | 30 |
| Cabling for Sony DXC-390 Color Cameras .....             | 32 |
| Configuring Sony XC-55 Cameras .....                     | 32 |
| Configuring Sony XC-ES Cameras .....                     | 33 |
| Configuring Sony XC-HR Cameras .....                     | 35 |
| Configuring Sony XC-ST Cameras .....                     | 36 |
| Configuring Teli CS8541D Cameras .....                   | 37 |
| Configuring Toshiba IK-53V Cameras .....                 | 38 |
| Connecting Cameras .....                                 | 40 |
| Connecting Parallel I/O Devices .....                    | 41 |
| Connecting TTL I/O Devices .....                         | 42 |
| Connecting I/O Devices with All Opto-Isolation .....     | 43 |
| Connecting I/O Devices with Partial Opto-Isolation ..... | 44 |
| ■ <b>Chapter 2: MVS-8500 Series Hardware</b> .....       | 47 |
| MVS-8500 Series Components .....                         | 48 |
| PCI Bus Interface .....                                  | 48 |

## ■ Contents

---

|  |    |
|--|----|
| PCI Express Bus Interface .....                                | 48 |
| Video Acquisition Interface .....                              | 48 |
| Model Differences .....  | 49 |
| MVS-8500 Series Revision History .....                         | 51 |
| Parallel I/O .....   | 52 |
| Image Acquisition and Video Output .....                       | 53 |
| Mechanical Specifications .....                                | 54 |
| MVS-8501 and MVS-8504 Layout .....                             | 54 |
| MVS-8511 and MVS-8514 Layout .....                             | 55 |
| MVS-8500Le, MVS-8511e, MVS-8504e, and MVS-8514e Layout .....   | 56 |
| Connector Summary .....  | 57 |
| Environmental Requirements .....                               | 58 |
| Shipping .....   | 58 |
| Standards Compliance .....                                     | 59 |
| International .....  | 59 |
| Electrical Specifications .....                                | 60 |
| Power Requirements .....                                       | 60 |
| MVS-8501 and MVS-8504 0200 Version Power Requirements .....    | 60 |
| MVS-8501 and MVS-8504 0236 Version Power Requirements .....    | 61 |
| MVS-8511 and MVS-8514 3094 Version Power Requirements .....    | 61 |
| MVS-8500Le and MVS-8504e 3004 Version Power Requirements ..... | 62 |
| MVS-8511e and MVS-8514e 3095 Version Power Requirements .....  | 62 |
| Fuses .....  | 62 |
| Camera Connector .....   | 63 |
| Analog Video Input Circuit .....                               | 64 |
| Options for Connecting Cameras .....                           | 66 |
| Monochrome Breakout Cables, Cameras Only .....                 | 66 |
| Monochrome Breakout Cable with Power Input .....               | 67 |
| Choosing a Monochrome Breakout Cable .....                     | 69 |
| Color+Monochrome Breakout Cable .....                          | 69 |
| Software Line Numbers .....                                    | 70 |
| Hirose Connector Pinout .....                                  | 70 |
| Camera Cables for Supported Cameras .....                      | 71 |
| Triggers, Strokes, and Parallel I/O Connector .....            | 71 |
| Connecting Devices .....                                       | 73 |
| Pinout of Parallel I/O Connector .....                         | 74 |
| Line Numbering .....   | 75 |
| Parallel I/O Circuit Logic .....                               | 76 |
| Notes on Parallel I/O Circuitry .....                          | 76 |
| When Configuring As Outputs .....                              | 77 |
| When Configuring As Inputs .....                               | 77 |

|   |     |
|---|-----|
| TTL I/O Connection Module .....                               | 78  |
| Cable from MVS-8500 Series to TTL I/O Module .....            | 78  |
| Layout of TTL I/O Connection Module .....                     | 80  |
| Specifications of TTL I/O Connection Module .....             | 80  |
| TTL I/O Connection Module Terminals .....                     | 81  |
| Opto-Isolated I/O Connection Module .....                     | 83  |
| Full Opto Cable from MVS-8500 Series to Opto I/O Module ..... | 83  |
| Half Opto Cable from MVS-8500 Series to Opto I/O Module ..... | 85  |
| Layout of Opto-Isolated I/O Connection Module .....           | 88  |
| Specifications of Opto-Isolated I/O Module .....              | 89  |
| Opto-Isolated I/O Module LED Numbering .....                  | 90  |
| Opto-Isolated I/O Module Adds Conversion Delay .....          | 90  |
| Opto-Isolated I/O Module Wiring Methods .....                 | 91  |
| Opto-Isolated I/O Module Circuit Logic .....                  | 92  |
| Opto-Isolated I/O Module Input Terminals .....                | 93  |
| Input Block Pinout with Full Opto Cable .....                 | 94  |
| Input Block Pinout with Half Opto Cable .....                 | 95  |
| Opto-Isolated I/O Module Output Terminals .....               | 96  |
| Output Block Pinout with Full Opto Cable .....                | 96  |
| Output Block Pinout with Half Opto Cable .....                | 97  |
| Hirose HR10 Connector Description .....                       | 99  |
| Pin Numbering of HR10 Jacks and Plugs .....                   | 100 |
| <b>Index</b> .....  | 103 |

## ■ Contents

---

# Preface

---

This manual describes the Cognex MVS-8500 series frame grabbers:

Chapter 1, *MVS-8500 Series Installation*, describes how you configure and install an MVS-8500 series frame grabber.

Chapter 2, *MVS-8500 Series Hardware*, describes the MVS-8500 series hardware, including environmental and power requirements, and its mechanical and electrical specifications.

## Note on Terminology

Throughout this manual:

- The terms ***MVS-8501***, ***MVS-8511***, ***MVS-8504***, and ***MVS-8514*** are used when discussing features specific to frame grabbers that plug into the PCI bus. The term ***MVS-8500/8510*** refers all PCI-bus boards.
- The terms ***MVS-8500Le***, ***MVS-8511e***, ***MVS-8504e***, and ***MVS-8514e*** are used when discussing features specific to frame grabbers that plug into the PCI Express bus. The term ***MVS-8500e/8510e*** refers all PCI Express-bus boards.
- The term ***MVS-8500 series frame grabber*** are used when discussing features common to all of the boards described in this manual.
- ***PCI*** refers to 32-bit PCI card slots, while PCI-X refers to 64-bit (extended) PCI card slots.
- ***PCIe*** refers to the PCI Express bus.
- Frame grabber names are sometimes abbreviated, dropping the MVS- prefix. For example, ***8504***, ***8514e*** or ***8504e***.

## MVS-8500 Series Naming Convention

The MVS-8500 series of frame grabbers include multiple board types, PC bus types, and number of camera channels. The naming scheme for the MVS-8500 series can help you identify the specific characteristics of an individual MVS-8500 series device based on its name, as shown in Figure 1.

### MVS-85gcb

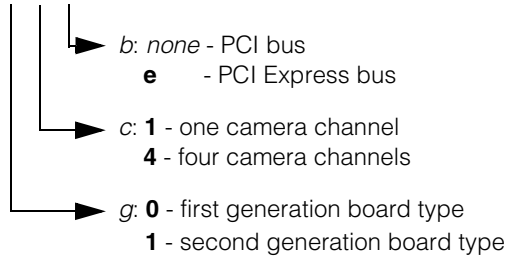

**MVS-8514e** Second-generation board type, 4-channel, PCI Express

**MVS-8501** First-generation board type, 1-channel, PCI bus

Figure 1. MVS-8500 series naming

**Note**

The MVS-8500Le does not conform to this naming convention. It has a first-generation board type, one camera channel, and supports the PCI Express bus.

## Compatibility Notes

There have been two major upgrades to the MVS-8500 series:

- The introduction of support for the PCI Express bus, which brought about the following new frame grabbers:
  - MVS-8500Le
  - MVS-8504e
- The introduction of the second-generation board type, which brought about the following new frame grabbers:
  - MVS-8511 (superseded MVS-8501)
  - MVS-8514 (superseded MVS-8504)



- MVS-8511e (superseded MVS-8500Le)
- MVS-8514e (superseded MVS-8504e)

This section describes compatibility information for each of these major upgrades. You can use the information in this section to determine what, if any, changes you may need to make to move to a new MVS-8500 series frame grabber

## Software Compatibility

For both the CVL and VisionPro software frameworks, you use exactly the same programming statements regardless of the specific MVS-8500 series frame grabber model.

- For CVL, you instantiate an instance of the **cc8501**, **cc8504**, or **cc8500l** class.
- For VisionPro, you use the **CogFrameGrabber8501**, **CogFrameGrabber8504**, or **CogFrameGrabber8500L** class.

To determine which MVS-8500 series model is installed, call the **name()** method on the object. The returned value will be one of the following:

- **Cognex 8501**
- **Cognex 8504**
- **Cognex 8511**
- **Cognex 8514**
- **Cognex 8504e**
- **Cognex 8511e**
- **Cognex 8514e**
- **Cognex 8500Le**

## Hardware Compatibility

This section lists hardware compatibility information between different MVS-8500 series models.

### PCI Express Bus Support (MVS-8500Le and MVS-8504e)

The MVS-8500e is an updated version of the MVS-8500 that connects to the PCI Express bus instead of the PCI bus. While the PCI Express frame grabbers are similar to the PCI frame grabbers, they are not backward-compatible. Users migrating from the MVS-8500

to the MVS-8500e will require an updated MVS-8500 driver and acquisition module, and may require changes to their user-written software. The following are things you may have to change:

- You may need to change your application source code and recompile your application.
- Images from an MVS-8500e may differ in grey values than those from an MVS-8500. You may need to fine tune contrast and brightness.
- If you are migrating to an MVS-8500Le, be aware it supports only 2 cameras, not 4, and that it supports only 8 parallel I/O lines, not 16.

### **Second Generation Board Type (MVS-8511, MVS-8514, MVS-8511e, and MVS-8514e)**

The MVS-8511, MVS-8514, MVS-8511e, and MVS-8514e (which supersede the MVS-8501, MVS-8504, MVS-8500Le, and MVS-8504e) make use of an updated analog-to-digital converter. While the new boards are very similar to the first-generation boards, they are not backward-compatible. Users migrating from a first generation board to a second generation board must use an updated MVS-8500 driver and acquisition module (see the additional information supplied with your MVS-8500 series frame grabber).

### **Contrast and Brightness Settings on MVS-8500 Series Frame Grabbers**

Contrast and brightness settings are made in CVL with functions of the **ccContrastBrightnessProp** class. Within the commonly used range of 0.05 to 0.95 for contrast and 0.20 to 0.80 for brightness settings, the grey level values in acquired images will vary slightly depending on which board you are using.

- At the same contrast and brightness settings, the MVS-8511, MVS-8511e, MVS-8514, and MVS-8514e frame grabbers produce grey level values that may be up to 10 grey levels higher or 6 grey levels lower than the pixel values produced by the MVS-8501 and MVS-8504 frame grabbers using the same input signal. The median difference in grey values across the full range of inputs is approximately 0.
- At the same contrast and brightness settings, the MVS-8511, MVS-8511e, MVS-8514, and MVS-8514e frame grabbers produce grey level values that may be up to 4 grey levels higher or 12 grey levels lower than the pixel values produced by the MVS-8500Le and MVS-8504e frame grabbers using the same input signal. The median difference in grey values across the full range of inputs is approximately -2 (the values produced by the newer frame grabbers are lower).

You may be able to minimize the grey value differences for a particular range of input values by adjusting the brightness and contrast settings.

## Internal Drive RGB Color Cameras

If you are using an Internal Drive RGB color camera (3-channel master/slave/slave with the frame grabber supplying drive signals to the camera) and on the 4<sup>th</sup> channel one monochrome camera on an MVS-8514 or MVS-8514e, you may observe a behavior difference from the MVS-8504 and MVS-8504e. On an MVS-8514 or MVS-8514e, in order to initialize the frame grabber for use with the 3-channel RGB camera, a reset of the clock generator is required. The clock generator also provides the clock for the 4<sup>th</sup> channel. Therefore, if the 4<sup>th</sup> channel is actively acquiring images, then the initialization of the RGB camera will fail until the acquisition on the 4<sup>th</sup> channel is stopped. Therefore, you must ensure there is no active acquisition on the 4<sup>th</sup> channel, then initialize the frame grabber for use with the RGB camera, and then restart acquisition on the 4<sup>th</sup> channel.

This behavior does not apply when the frame grabber locks to sync signals from an RGB color camera.

## Board Ordering

If you are using multiple MVS-8500 series frame grabbers in a single PC, replacing one or more existing MVS-8501, MVS-8500Le, MVS-8504, or MVS-8504e frame grabbers with a new MVS-8511, MVS-8511e, MVS-8514, or MVS-8514e frame grabber may cause your application code to return frame grabber instances in a different order. This section describes, for both CVL and VisionPro, how frame grabber instances are enumerated and returned, the circumstances under which the order may change, and how to handle this condition.

### CVL

You use the following CVL functions to determine the number of frame grabbers that are present in this PC:

- **ccBoard::count()** returns the total number of frame grabbers of any type in the system.
- **cc8500l::count()** returns the total number of MVS-8500Le frame grabbers in the system.
- **cc8501::count()** returns the total number of MVS-8501, MVS-8511, and MVS-8511e frame grabbers in the system.
- **cc8504::count()** returns the total number of MVS-8504, MVS-8514, MVS-8504e, and MVS-8514e frame grabbers in the system.

You use the following CVL functions to obtain an object instance that corresponds to a particular frame grabber:

- **ccBoard::get(index i)** returns an object instance that corresponds to the frame grabber with the specified index. For this function, the installed frame grabbers are sorted in name order, as listed here:

## ■ Preface

---

8500Le  
8501  
8504  
8504e  
8511  
8511e  
8514  
8514e

If multiple frame grabbers of different types are installed, then **ccBoard::get()** will return them in the order listed above. If, for example, you have an MVS-8504e and an MVS-8514e installed, **ccBoard::get(0)** will always return a reference to the MVS-8504e and **ccBoard::get(1)** will always return a reference to the MVS-8514e.

If multiple frame grabbers of the *same type* are installed, then the order in which the boards are installed is undefined. For a given set of boards installed in given slots in a given PC, the order will always be the same, but the particular order cannot be determined other than by comparing the serial number of the boards.

If, for example, you have an existing PC with two MVS-8504 boards installed, they will always be returned in the same order. If you replace one of the boards with an MVS-8514, then the existing MVS-8504 board will always be returned first, the new MVS-8514 will be returned second. Since the order in which the two existing MVS-8504 boards was returned was undefined, the new behavior may be different. There is no way to determine if the order is changed other than by calling **ccBoard::get(0)** and **ccBoard::get(1)** before and after changing the board.

### Note

The board order returned by **ccFrameGrabber::get()** is exactly the same as the board order returned by **ccBoard::get()**, except that **ccBoard** returns information for Cognex Security keys as well as frame grabbers (or other Cognex hardware), while **ccFrameGrabber** only returns information about frame grabbers.

- **cc8500l::get(index i)** returns an object instance that corresponds to the MVS-8500Le frame grabber with the specified index. The order in which the frame grabbers are returned by this function is undefined. For a given set of boards installed in given slots in a given PC, the order will always be the same, but the particular order cannot be determined other than by comparing the serial number of the boards.
- **cc8501::get(index i)** returns an object instance that corresponds to the MVS-8501, MVS-8511, or MVS-8511e frame grabber with the specified index. The order in which the frame grabbers are returned by this function is undefined. For a given set of boards installed in given slots in a given PC, the order will always be the same, but the particular order cannot be determined other than by comparing the serial number the boards.

- **cc8504::get(index i)** returns an object instance that corresponds to the MVS-8504, MVS-8514, MVS-8504e, or MVS-8514e frame grabber with the specified index. The order in which the frame grabbers are returned by this function is undefined. For a given set of boards installed in given slots in a given PC, the order will always be the same, but the particular order cannot be determined other than by comparing the serial number of the boards.

If, for example, you have an existing PC with two MVS-8504 boards installed, **cc8504::get()** will always return the boards in the same order. If you replace one of the boards with an MVS-8514, the order in which the two boards will be returned is undefined. There is no way to determine if the order is changed other than by calling **cc8504::get(0)** and **cc8504::get(1)** before and after changing the board.

If your CVL application depends for its correct operation upon particular boards being returned for particular index values, changing boards, board types, or slot positions may change that order. The only deterministic method for associating a particular software object instance with a particular physical board is to examine the value returned by **ccBoard::serialNumber()**.

## VisionPro

You use the following VisionPro properties to determine the number of frame grabbers that are present in this PC:

- **CogFrameGrabbers.Count** returns the total number of frame grabbers of any type in the system.
- **CogFrameGrabber8500Ls.Count** returns the total number of MVS-8500Le frame grabbers in the system.
- **CogFrameGrabber8501s.Count** returns the total number of MVS-8501, MVS-8511, and MVS-8511e frame grabbers in the system.
- **CogFrameGrabber8504s.Count** returns the total number of MVS-8504, MVS-8514, MVS-8504e, and MVS-8514e frame grabbers in the system.

You use the following VisionPro properties to obtain an object instance that corresponds to a particular frame grabber:

- The **CogFrameGrabbers.Item** property returns an object instance that corresponds to the frame grabber with the specified index. For this function, the installed frame grabbers are sorted in **name** order, as listed here:

```
8500Le
8501
8504
8504e
```

8511  
8511e  
8514  
8514e

If multiple frame grabbers of different types are installed, then **CogFrameGrabbers.Item** will return them in the order listed above. If, for example, you have an MVS-8504e and an MVS-8514e installed, **CogFrameGrabbers[0]** will always return a reference to the MVS-8504e and **CogFrameGrabbers[1]** will always return a reference to the MVS-8514e.

If multiple frame grabbers of the same type are installed, then the order in which the boards are installed is undefined. For a given set of boards installed in given slots in a given PC, the order will always be the same, but the particular order cannot be determined other than by enumerating the boards.

If, for example, you have an existing PC with two MVS-8504 boards installed, they will always be returned in the same order. If you replace one of the boards with an MVS-8514, then the existing MVS-8504 board will always be returned first, the new MVS-8514 will be returned second. Since the order in which the two existing MVS-8504 boards was returned was undefined, the new behavior may be different. There is no way to determine if the order is changed other than by examining the value of **CogFrameGrabbers[0]** and **CogFrameGrabbers[1]** before and after changing the board.

- The **CogFrameGrabber8500Ls.Item** property returns an object instance that corresponds to the MVS-8500Le frame grabber with the specified index. The order in which the frame grabbers are returned by this function is undefined. For a given set of boards installed in given slots in a given PC, the order will always be the same, but the particular order cannot be determined other than by comparing the serial number of the boards
- The **CogFrameGrabber8501s.Item** property returns an object instance that corresponds to the MVS-8501, MVS-8511, or MVS-8511e frame grabber with the specified index. The order in which the frame grabbers are returned by this function is undefined. For a given set of boards installed in given slots in a given PC, the order will always be the same, but the particular order cannot be determined other than by comparing the serial number of the boards.
- The **CogFrameGrabber8504s.Item** property returns an object instance that corresponds to the MVS-8504, MVS-8514, MVS-8504e, or MVS-8514e frame grabber with the specified index. The order in which the frame grabbers are returned by this function is undefined. For a given set of boards installed in given slots in a given PC, the order will always be the same, but the particular order cannot be determined other than by comparing the serial number of the boards.

If, for example, you have an existing PC with two MVS-8504 boards installed, **CogFrameGrabber8504s.Item** will always return the boards in the same order. If you replace one of the boards with an MVS-8514, the order in which the two boards will be returned is undefined. There is no way to determine if the order is changed other than by examining the value of **CogFrameGrabbers[0]** and **CogFrameGrabbers[1]** before and after changing the board.

If your VisionPro application depends for its correct operation upon particular boards being returned for particular index values, changing boards, board types, or slot positions may change that order. The only deterministic method for associating a particular software object instance with a particular physical board is to examine the value of the **ICogFrameGrabber.SerialNumber** property.

# Style Conventions Used in This Manual

This manual uses the style conventions described in this section for text and software diagrams.

## Text Style Conventions

This manual uses the following style conventions for text:

|                      |  |
|----------------------|--|
| <b>boldface</b>      | Used for C/C++ keywords, function names, class names, structures, enumerations, types, and macros. Also used for user interface elements such as button names, dialog box names, and menu choices. |
| <i>italic</i>        | Used for names of variables, data members, arguments, enumerations, constants, program names, file names. Used for names of books, chapters, and sections. Occasionally used for emphasis.         |
| <code>courier</code> | Used for C/C++ code examples and for examples of program output.   |
| <b>bold courier</b>  | Used in illustrations of command sessions to show the commands that you would type.  |
| < <i>italic</i> >    | When enclosed in angle brackets, used to indicate keyboard keys such as <Tab> or <Enter>.  |

## Microsoft Windows Support

Cognex CVL and VisionPro software run on Windows XP and Windows 7 operating systems. In this documentation set, these are abbreviated to Windows unless discussing a feature unique to a specific operating system. Consult your CVL *Getting Started* manual or VisionPro *Quick Reference* for the list of operating systems, hardware, and software supported by your release.



# Cognex Offices

The following are the address and phone number of Cognex Corporate Headquarters, and the address of the Cognex web site:

**Corporate Headquarters**

Cognex Corporation  
Corporate Headquarters  
One Vision Drive  
Natick, MA 01760-2059  
(508) 650-3000

**Web Site**

<http://www.cognex.com>

■ **Preface**

---

**NOTES**

---

# MVS-8500 Series Installation

# 1

This chapter describes how to install MVS-8500 series frame grabbers into your PC, how to connect one or more cameras to the frame grabber, and how to connect peripheral equipment such as triggers, strobes, and other I/O devices.

## Note on Terminology

Throughout this manual:

- The terms **MVS-8501**, **MVS-8511**, **MVS-8504**, and **MVS-8514** are used when discussing features specific to frame grabbers that plug into the PCI bus. The term **MVS-8500/8510** refers all PCI-bus boards.
- The terms **MVS-8500Le**, **MVS-8511e**, **MVS-8504e**, and **MVS-8514e** are used when discussing features specific to frame grabbers that plug into the PCI Express bus. The term **MVS-8500e/8510e** refers all PCI Express-bus boards.
- The term **MVS-8500 series frame grabber** is used when discussing features common to all of the boards described in this manual.
- **PCI** refers to 32-bit PCI card slots, while PCI-X refers to 64-bit (extended) PCI card slots.
- **PCIe** refers to the PCI Express bus.
- Frame grabber names are sometimes abbreviated, dropping the MVS- prefix. For example, **8500**, **8504**, **8514e** or **8504e**.

# Host PC Requirements

To install an MVS-8500 series frame grabber, the host PC should meet the following minimum requirements:

- For MVS-8500/8510 frame grabbers the motherboard's chip set must be fully compliant with the PCI 2.1, 2.2, or 2.3 specifications. Motherboards with Intel chip sets that support Intel Pentium, Pentium III, Pentium 4, and Xeon CPUs are known to be compliant. Motherboards with VIA chip sets that support the AMD K6-III, and Athlon CPUs are known to be compliant.
  - One available PCI or PCI-X card slot.
- For MVS-8500e/8510e frame grabbers the motherboard's chip set must be fully compliant with the PCI Express Revision 1.0a, 1.1, or 2.0 specifications. Motherboards with Intel chip sets that support Intel Pentium 4, Pentium D, Core Duo, Core 2 Duo and Xeon CPUs are known to be compliant.
  - One available PCI Express card slot.
- One available CD-ROM or DVD drive (or access to one over a network) to install the Cognex software.

Additional requirements may be imposed by your Cognex software package. Check the Cognex software's release notes or *Getting Started* manual for the software's requirements, if any, on:

- Minimum recommended CPU speed
- Host operating system, including the supported service pack release level
- Supported video cards
- Desktop color depth (the number of colors displayable)
- Desktop size (the number of pixels displayable in width and height on your screen)
- The presence of a mouse or other pointing device

# Installing the MVS-8500 Series

This section describes the steps to prepare for installation and to install an MVS-8500 series frame grabber. The following section describes how to select and install an MVS-8500/8510 frame grabber in a PC with a PCI or PCI-X bus. See *MVS-8500e/8510e: Selecting a PCI Express Slot* below on page 23 for a description of installing an MVS-8500e/MVS-8510e in a PC with a PCI Express bus.

## MVS-8500/8510: Selecting a PCI Slot

The MVS-8500/8510 has a universal PCI interface, compatible with 5 V and 3.3 V systems.

The MVS-8501 and MVS-8511 support standard 33 MHz operation when placed in any PCI or PCI-X slot. The MVS-8501 and MVS-8511 do not support 66 MHz operation.

The MVS-8504 and MVS-8514 support both 33 MHz and 66 MHz operation. They support 66 MHz operation under the following conditions:

- The PC's motherboard and chipset must support 66 MHz PCI or PCI-X operation
- The MVS-8504 or MVS-8514 must be installed in a PCI or PCI-X slot that supports 66 MHz operation
- No 33 MHz PCI cards can be installed on the same 66 MHz PCI or PCI-X bus segment

The MVS-8504 or MVS-8514 operates as a standard 33 MHz PCI card:

- If placed in a standard 33 MHz PCI slot
- If placed in a 66 MHz PCI or PCI-X slot, but one of the conditions above is not met

## Identifying a 66 MHz PCI Slot

A provision for supporting 66 MHz operation has been part of the PCI specification since specification version 2.1. Actual support for 66 MHz operation has been generally limited to server or workstation class motherboards.

66 MHz operation is usually associated with 64-bit PCI slots, but the two features are not the same. While 66 MHz operation will usually be found in a 64-bit PCI or PCI-X slot, you cannot presume that all 64-bit PCI slots support 66 MHz operation. You can identify 64-bit PCI slots by their extended size, as shown in Figure 2 on page 22.

A motherboard that supports 66 MHz operation will usually place the 66 MHz PCI slots on a separate PCI bus or bus segment than the 33 MHz PCI slots.

As a general rule, to achieve 66 MHz operation, place the MVS-8504 or MVS-8514 in a 64-bit PCI or PCI-X slot, and make sure that no 33 MHz PCI boards are placed in another 64-bit slot on the same motherboard. However, there is no physical marker that identifies 66 MHz operation. Only the PC or motherboard documentation can validate:

- Whether 66 MHz operation is supported
- Which PCI slots are on the same PCI bus or bus segment

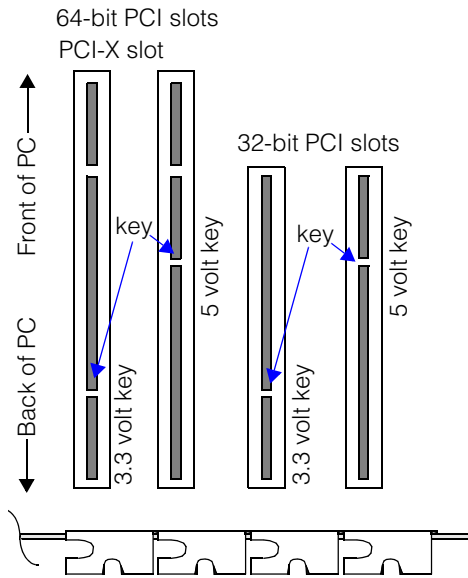

Figure 2. PCI slot types

## PCI-X Slots

Beginning in 2003, motherboards became available with PCI Extended (PCI-X) slots. PCI-X slots are 64-bit slots that support 66 MHz or faster operation. An MVS-8504 or MVS-8514 operates at 66 MHz in a PCI-X slot, as long as no standard 33 MHz PCI card is placed on the same PCI-X bus segment.

**Note** Although both the MVS-8504 or MVS-8514 can operate in a 64-bit slot, neither board runs in 64-bit mode, only 32-bit mode.

## MVS-8500e/8510e: Selecting a PCI Express Slot

The MVS-8500e/8510e has an x1 PCI Express bus interface. PCI Express card slots come in four sizes: x1, x4, x8 and x16 as shown in Figure 3 below.

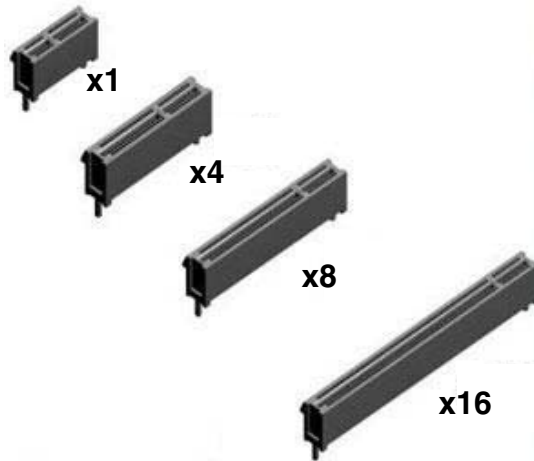

Figure 3. PCI Express card slots

The MVS-8500e/8510e has an x1 bus and can be placed in any x1, x4, x8, or x16 PCI Express slot.

## Installation Steps

To install an MVS-8500 series frame grabber, follow these steps:

**Caution**      *Electrostatic discharge (ESD) can damage the electronic components of your Cognex hardware.*

1. Wear a grounded, static-dissipating wrist strap for ESD protection.
2. Power off the PC and remove its cover.
3. Select an expansion slot for the frame grabber using the information in the previous sections as a guide. Remove the slot cover and store it for future use.
4. Press the board into its slot until it is seated firmly.
5. Connect a power supply from the PC to the external power connector on the upper rear corner of the frame grabber. The connector is labeled J3 on MVS-8501 and MVS-8504 boards and J2 on all other MVS-8500 series boards.

For the MVS-8501 and MVS-8504, the external power connector requires a +12 V

power source. All of the power supplied through the external connector is available for powering external cameras; none is used by the board itself.

The MVS-8501 and MVS-8504 connection is shown in Figure 4 below. You can use the Cognex power adapter cable 300-0391 to connect the board to a standard 4-pin PC power connector, as shown in Figure 4.

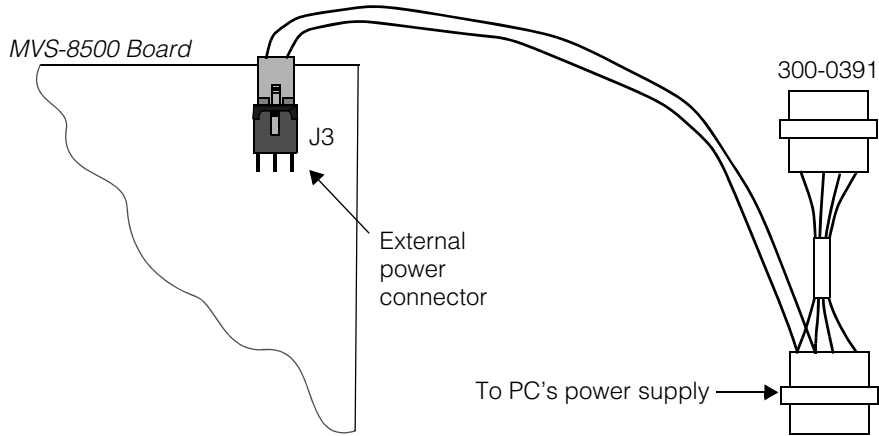

Figure 4. MVS-8500 external power connector

Cognex cable 300-0175 can be used in place of 300-0391 for short-term development purposes. However, cable 300-0175 does not lock into place on the MVS-8501 or MVS-8504's J3 connector, and should not be used in deployed systems.



If your PC has SATA power connectors rather than PATA (4-pin) power connectors, you can use the adapter supplied with Cognex power adapter cable 300-0391 to connect the MVS-8501 or MVS-8504 to a SATA power connector, as shown in Figure 5.

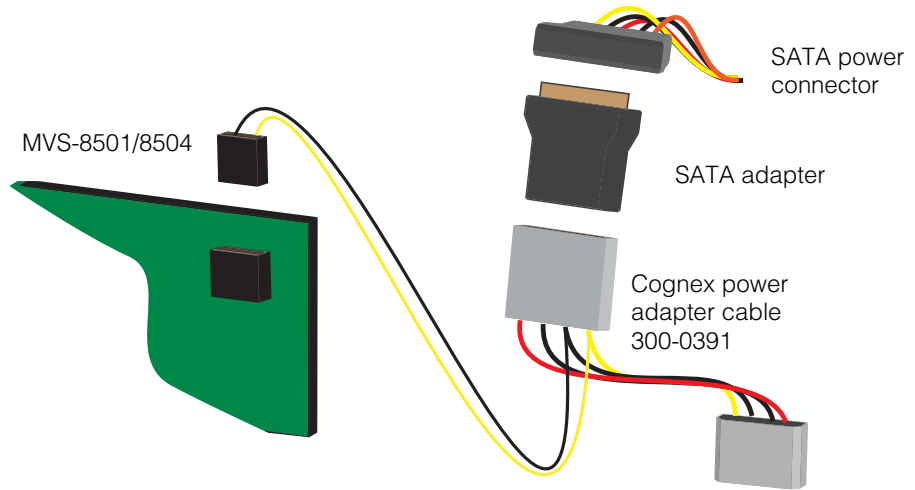

Figure 5. SATA adapter (MVS-8500)

The MVS-8511, MVS-8514, and MVS-8500e/8510e external power connector requires both +5 V and +12 V power. The +12 V power is sent directly to the cameras and is not used on board, but the +5 V power *is* used by the frame grabber. If the MVS-8511, MVS-8514, or MVS-8500e/8510e is not connected to an external +5 V power supply, it will not operate.

You can connect a standard 4-pin PC power cable directly to the J2 connector on the MVS-8511, MVS-8514, or MVS-8500e/8510e, as shown in Figure 6.

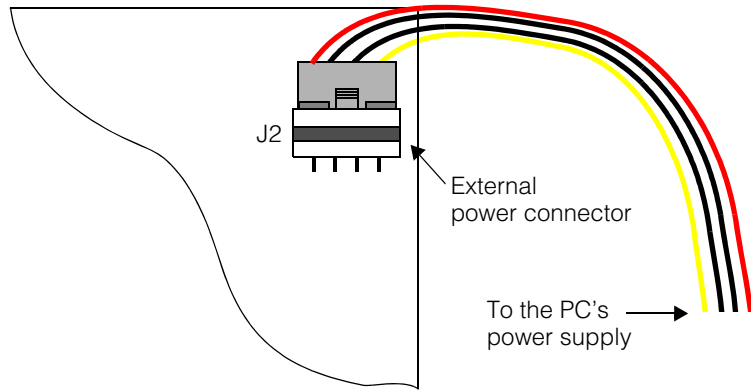

Figure 6. MVS-8511, MVS-8514, and MVS-8500e/8510e external power connection

6. If your PC uses faceplate screws, replace the faceplate screw to anchor the frame grabber so that it does not loosen when attaching and removing cameras.
7. Replace your PC's cover.

**Caution**

*Do not power on the PC until you have connected cameras and any parallel I/O devices to the frame grabber.*

# Configuring Cameras

This section describes the setup steps for the cameras that require special settings for use with MVS-8500 series frame grabbers.

## Configuring JAI CV-A1 Cameras

The MVS-8500 series supports the use of the JAI CV-A1 large format, progressive scan camera. If you purchase your CV-A1 cameras from Cognex, they arrive configured and ready to use. If you purchase your CV-A1 from a third party, you must configure the camera as described in this section.

Configure the JAI CV-A1 by connecting a serial cable between the camera and a PC running Windows. Then run JAI's Camera Control Tool (CCT), which is downloadable from JAI's web site, [www.jai.com](http://www.jai.com).

Construct a serial cable, or obtain one from JAI. One end of this cable must have a Hirose HR10A-7P-6S connector (7 mm plug, 6-pin female). This end connects to the 6-pin Hirose connector on the CV-A1. The other end of the cable should have a DB-9F or DB-25F connector, whichever matches the serial ports of the PC running the Camera Control Tool. You only need to connect TXD, RXD, and GND signal lines, using your JAI and PC documentation for pinout information. Map the CV-A1's TXD line to the RXD line on the PC's serial port, and map the camera's RXD to the PC's TXD.

1. Apply power to the CV-A1 camera.
2. Connect the serial cable to the CV-A1 camera and to an available serial port on the controlling PC.
3. Start the CV-A1 Control Tool; this displays a single toolbar with seven buttons.
4. Click the sixth button to display the **Communication** dialog.
  - a. In the **Communication Port** drop-down, select the serial port you selected in step 2, or click the **Auto** button.
  - b. Wait for the word *On-line* to show in the **Status** section.
  - c. The **Synchronize** section may show "Not Synchronized." Ignore this for now.
5. Click the first button, which opens the **Shutter and Sync Signals** dialog. Configure the fields of this dialog as follows:

| Control             | Setting             |
|---------------------|---------------------|
| <b>Shutter Mode</b> | Normal              |
| <b>Trigger Mode</b> | Pulse Width Control |

| Control                            | Setting     |
|------------------------------------|-------------|
| <b>Trigger Polarity</b>            | Active L    |
| <b>HD Synchronous Accumulation</b> | Async       |
| <b>Pixel Clock Out</b>             | Off         |
| <b>Partial Scan Mode</b>           | Full Frame  |
| <b>EEN/WEN</b>                     | WEN         |
| <b>WEN Polarity</b>                | Active L    |
| <b>Sync Signal Output</b>          | On          |
| <b>Binning</b>                     | Binning OFF |

6. Click the sixth button to reopen the **Communication** dialog.
  - a. Click the **Synchronize Camera** button and wait for the confirmation "Synchronized."
7. Click the fifth button to open the **Files and Camera** dialog.
  - a. Select the same *User n* setting for both **Factory and User Settings in Camera** and **Initial Data**. For example, select "User 1" for both fields.
  - b. Click the **Store Settings** button
  - c. Click the **Write to Camera** button.
  - d. Optionally, click the **Write to File** button to save the current camera settings to the file of your choice.
8. Disconnect the serial cable from the camera and PC.

The CV-A1 is now configured to work with the MVS-8500 series. The camera will power up with these settings until you change them.

## Configuring JAI CV-A2 Cameras

The MVS-8500 series supports the use of the JAI CV-A2 large format, progressive scan camera. If you purchase your CV-A2 cameras from Cognex, they arrive configured and ready to use. If you purchase your CV-A2 from a third party, you must configure the camera as described in this section.

Configure the JAI CV-A2 by connecting a serial cable between the camera and a PC running Windows. Then run JAI's CV-A2 Camera Control Tool (CCT), which is downloadable from JAI's web site, [www.jai.com](http://www.jai.com).

Construct a serial cable, or obtain one from JAI. One end of this cable must have a Hirose HR10A-7P-6S connector (7 mm plug, 6-pin female). This end connects to the 6-pin Hirose connector on the CV-A2. The other end of the cable should have a DB-9F or DB-25F connector, whichever matches the serial ports of the PC running the Camera Control Tool. You only need to connect TXD, RXD, and GND signal lines, using your JAI and PC documentation for pinout information. Map the CV-A2's TXD line to the RXD line on the PC's serial port, and map the camera's RXD to the PC's TXD.

1. Apply power to the CV-A2 camera.
2. Connect the serial cable to the CV-A2 camera and to an available serial port on the controlling PC.
3. Start the CV-A2 Control Tool; this displays a single toolbar with several buttons.
4. Click the **Communication** button to display the **Communication** dialog.
  - a. In the **Communication Port** drop-down, select the serial port you selected in step 2, or click the **Auto** button.
  - b. Wait for the word *On-line* to show in the **Status** section.
  - c. The **Synchronize** section may show "Not Synchronized." Ignore this for now.
  - d. Click the **Synchronize Camera** button and wait for the confirmation "Synchronized." This indicates that the Control Tool is displaying the actual values from the camera.
5. In the **Camera Control** window, specify the following values:

| <b>Control</b>                         | <b>Setting</b>                            |
|--|---|
| <b>Shutter Mode</b>                    | Normal                                    |
| <b>Shutter Speed</b>                   | OFF                                       |
| <b>Partial Scan Mode</b>               | Full Frame                                |
| <b>Gain Setup</b>                      | Manual Gain                               |
| <b>Rear Potentiometer Gain Control</b> | ON or OFF, depending on your application. |
| <b>Trigger Mode</b>                    | Pulse Width Control                       |
| <b>Trigger Polarity</b>                | Active L                                  |
| <b>Pixel Clock Out</b>                 | OFF                                       |
| <b>HD Synchronous Accumulation</b>     | Async                                     |
| <b>EEN/WEN</b>                         | WEN                                       |

| Control                   | Setting                             |
|---------------------------|-------------------------------------|
| <b>WEN Polarity</b>       | Active L                            |
| <b>Sync Signal Output</b> | ON                                  |
| <b>Binning</b>            | OFF                                 |
| <b>Iris Select</b>        | Video Out                           |
| <b>Sensor Gate Invert</b> | Normal                              |
| <b>Sensor Gate</b>        | Trig Mode                           |
| <b>Black Level</b>        | Do not change (use factory default) |
| <b>White Clip Level</b>   | Do not change (use factory default) |

6. Reopen the **Communication** dialog.
  - a. Click the **Synchronize Camera** button and wait for the confirmation "Synchronized." This indicates that the Control Tool has written the new values to the camera.
7. Open the **Files and Camera** dialog.
  - a. Select the same *User n* setting for both **Factory and User Settings in Camera** and **Initial Data**. For example, select "User 1" for both fields.
  - b. Click the **Store Settings** button
  - c. Click the **Write to Camera** button.
  - d. Optionally, click the **Write to File** button to save the current camera settings to the file of your choice.
8. Disconnect the serial cable from the camera and PC.

The CV-A2 is now configured to work with the MVS-8500 series. The camera will power up with these settings until you change them.

## Configuring Sony DXC-390 Color Cameras

The MVS-8504, MVS-8514, MVS-8504e, and MVS-8514e support the use of the Sony DXC-390 color camera. If you purchase your DXC-390 camera from Cognex, it arrives configured and ready to use.

**Note** Sony DXC-390 cameras purchased from Cognex may be labeled DXC-390/C on the camera body or on the shipping box or both. The /C designation applies to cameras that have been set up as described in the following steps.

If you purchase your Sony DXC-390 from a third party, you must configure the camera as shown in the following steps.

The following procedure expands the effective horizontal imaging area of the DXC-390 by 200 ns per line, and reduces the video noise level.

1. Remove and carefully set aside the seven small screws that fasten the top cover of the DXC-390. Remove the top cover.
2. Locate switch S102 as shown in Figure 7.

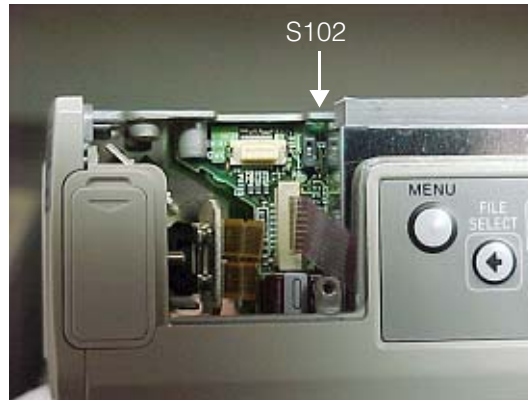

Figure 7. Sony DXC-390 with cover removed

3. Use a small screwdriver to move switch S102 to the down position, labeled ADJ.
4. Connect an NTSC monitor to the camera's composite video connector labeled VIDEO OUT.
5. Provide power to the camera through the Hirose connector labeled DC IN/VBS. Live video now displays on the monitor.

To provide +12 V power to the camera, you can connect the Hirose branch of the Cognex camera cable from an MVS-8504 or MVS-8504e in a powered-on PC, or you can provide power from a bench power supply.

6. Press the MENU button and observe the video monitor. With switch S102 in its normal up position, the MENU button displays a setup menu. With switch S102 in the down position, pressing MENU displays numeric registers plus one setup line of text at the bottom of the screen.

The bottom setup line reads "DSPAdj No. 00 Data 00" This is DSP adjustment number 00, containing the data value 00.

7. Press the ← and → buttons at the same time. This resets the setup line to its middle position, where the DSP adjustment number is 240, and data value is 8C.

8. Press the → button until the DSP adjustment number is 336. You can hold in the → button to fast forward the change in adjustment numbers.
9. At DSP adjustment number 336, press the ↑ or ↓ buttons as required to change the data value from 32 to 3C.
10. Press the ← and → buttons at the same time to return the setup line to DSP adjustment number 240 and data value 8C.
11. Press the ← button until the DSP adjustment number is 207. Hold the button in to fast forward.
12. At DSP adjustment number 207, press the ↑ or ↓ buttons as required to change the data value from F9 to 40.
13. Carefully slide switch S102 to its up position, labeled OPE. Press the MENU button to make sure the standard SETUP menu displays, and not the DSPAdj line.
14. Power off the camera by removing the Hirose cable from the DC IN/VBS connector. Then remove the video out cable, and replace and refasten the top cover on the DXC-390.

See section *Internal Drive RGB Color Cameras* on page 11 for timing configuration when using a 3-channel RGB camera together with a monochrome camera on an MVS-8514 or MVS-8514e.

## Cabling for Sony DXC-390 Color Cameras

The Sony DXC-390 color camera is supported on the MVS-8504, MVS-8514, MVS-8504e, and MVS-8514e frame grabbers. You can connect the DXC-390 directly to the frame grabber, or you can use a breakout cable that allows the connection of the DXC-390 plus one monochrome camera.

Use Cognex cable 300-0176 to connect directly to the frame grabber's camera port.

Use Cognex breakout cable 300-0406 as described in *Color+Monochrome Breakout Cable* on page 69.

## Configuring Sony XC-55 Cameras

The MVS-8500 series supports the use of the Sony XC-55 and XC-55BB cameras. If you purchase your XC-55 cameras from Cognex, they arrive configured and ready to use. If you purchase your XC-55 from a third party, you must configure the camera as shown in this section.



The XC-55/55BB, as shipped from Sony, is configured to emulate the Sony XC-75 camera. Cognex recommends instead using the XC-55/55BB in its E-DONPISHA II trigger shutter mode for best performance. Two switch settings convert the XC-55/55BB to trigger shutter mode; one switch is external, on the camera's rear panel, while the other switch is internal, under the camera's cover. Follow this procedure:

1. On the rear panel of the XC-55/55BB, locate the **1N/1L** switch. Place this switch in the **1N** position.
2. Remove the cover of the camera control unit. Inside the camera control unit, locate the circuit board labeled SG-257.
3. On the SG-257 circuit board, locate rotary switch **S2**, which is in the upper right of a set of four rotary switches as you hold the camera with its top cover up and the lens mount on the right. Set this switch to the **E** position.

## Configuring Sony XC-ES Cameras

The MVS-8500 series supports the Sony XC-ES50 family of cameras, including the XC-ES50 and XC-ES50CE. If you purchase your XC-ES50 cameras from Cognex, they arrive configured and ready to use. If you purchase your XC-ES50 from a third party, you must configure the camera as shown in this section.

Figure 8 shows the back panel of the Sony XC-ES50 camera with the switches in their factory default and rapid reset modes.

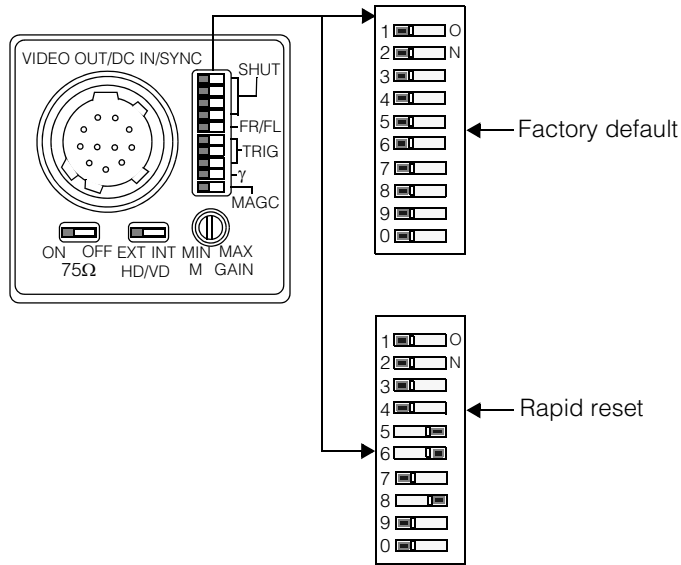

Figure 8. Sony XC-ES50 camera back panel

To configure the switches for the Sony XC-ES50 camera:

1. Configure the 10-position DIP switch as shown in Figure 8.

**Note**

You can set switch 5 to ON in factory default mode to use field integration rather than frame integration (single field and half-resolution video formats only).

2. Set the manual gain switch in the fully vertical position.
3. Set the HD/VD switch to external (EXT).
4. Set the 75Ω switch to ON.

## Configuring Sony XC-HR Cameras

When using Sony XC-HR family cameras (HR50, HR57, HR58, HR70, and HR90) with MVS-8500 series frame grabbers, use the following steps to configure your camera to use E-DONPISHA II trigger shutter, progressive scan, and asynchronous reset.

1. Disconnect all electrical connections from the camera before changing the switches.
2. Locate the 10-bit DIP switch block on the back of the camera. Set the switches as shown in Table 1.

| DIP Switch | Setting |
|------------|---------|
| 1          | OFF     |
| 2          | OFF     |
| 3          | OFF     |
| 4          | OFF     |
| 5          | OFF     |
| 6          | OFF     |
| 7          | ON      |
| 8          | ON      |
| 9          | OFF     |
| 0          | OFF     |

Table 1. DIP switch settings for Sony XC-HR50, XC-HR57, XC-HR58, XC-HR70, and XC-HR90

3. For **HR50**, **HR57**, **HR58**, and **HR70** cameras, locate the switch labeled **Int/Ext**. Set this switch to **Ext**.

For **HR90** cameras, set the second 4-bit DIP switch as shown in Table 2.

| DIP Switch | Setting |
|------------|---------|
| 1          | ON      |
| 2          | ON      |

Table 2. DIP switch settings for Sony XC-HR90

| DIP Switch | Setting                        |
|------------|--------------------------------|
| 3          | OFF* (ON for 15 FPS Operation) |
| 4          | OFF                            |

Table 2. DIP switch settings for Sony XC-HR90

## Configuring Sony XC-ST Cameras

The MVS-8500 series supports the Sony XC-ST family of cameras, including the XC-ST50 and XC-ST50CE. If you purchase your XC-ST50 cameras from Cognex, they arrive configured and ready to use. If you purchase your XC-ST50 cameras from a third party, you must configure the cameras as shown in this section.

Figure 9 shows the back panel of the Sony XC-ST50 camera with the switches in their factory default and rapid reset modes.

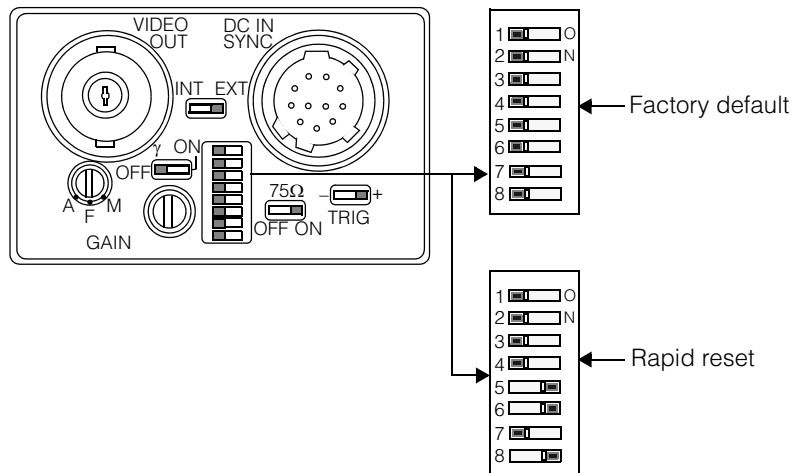

Figure 9. Sony XC-ST50 camera back panel

To configure the switch for the Sony XC-ST50 camera:

1. Configure the 8-position DIP switch as shown in Figure 9.

**Note** Set switch 5 to ON in factory default mode to use field integration rather than frame integration (single field and half-resolution video formats only).

2. Set gain to the “F” position.

3. Set the INT EXT switch to external (EXT).
4. Set TRIG to +.
5. Set gamma ( $\gamma$ ) to off.
6. Set the 75 $\Omega$  switch to ON.

## Configuring Teli CS8541D Cameras

When used with MVS-8500 series frame grabbers, configure a Teli CS8541D camera to use 1/60 second, non-interlaced, shuttered mode. Follow these steps:

1. Disconnect all electrical connections from the camera before changing the switches.
2. Locate the DIP switch block on the bottom of the camera control unit. Set the switches as shown in Table 3.

| Switch Function   | DIP Switch | Setting |
|-------------------|------------|---------|
| E shutter speed   | 1          | OFF     |
| E shutter speed   | 2          | ON      |
| E shutter speed   | 3          | ON      |
| Video output mode | 4          | OFF     |
| Shutter mode      | 5          | OFF     |
| Shutter mode      | 6          | OFF     |
| Partial scan      | 7          | OFF     |
| Partial scan      | 8          | OFF     |
| Trigger polarity  | 9          | OFF     |
| RTS exposure mode | 10         | ON      |

Table 3. DIP switch settings for Teli CS8541D camera

- Remove the cover of the camera control unit. Use the camera's Operations Manual to locate switches SW1, SW4, and SW5. Set these switches as shown in Table 4.

| Switch Function     | DIP Switch | Setting | Default setting |
|---------------------|------------|---------|-----------------|
| Video out coupling  | SW1        | AC      | DC              |
| E shutter speed     | SW4        | IN      | IN              |
| ExSync In Impedance | SW5        | 75      | High            |

Table 4. Internal switch settings for Teli CS8541D camera

- Replace the camera control unit's cover.
- Locate the switch labeled **Gain Control** on the side of camera's control unit. Set this switch to **Fix**.

## Configuring Toshiba IK-53V Cameras

When used with MVS-8500 series frame grabbers, configure Toshiba IK-53V cameras to use pulse width trigger, sync non-reset, full-resolution, progressive scan mode. Follow these steps:

- Disconnect all electrical connections from the camera before changing the switches.
- Locate the DIP switch block on the back of the camera. Set the switches as shown in Table 5.

| DIP Switch | Setting |
|------------|---------|
| 1          | OFF     |
| 2          | OFF     |
| 3          | OFF     |
| 4          | OFF     |
| 5          | ON      |
| 6          | ON      |
| 7          | OFF     |
| 8          | OFF     |

Table 5. DIP switch settings for Toshiba IK-53V camera

| <b>DIP Switch</b> | <b>Setting</b> |
|-------------------|----------------|
| 9                 | ON             |
| 0                 | OFF            |

*Table 5. DIP switch settings for Toshiba IK-53V camera*

# Connecting Cameras

For most cameras supported by the MVS-8500 series, you must attach a camera breakout cable to the frame grabber's DB-26F camera port. The breakout cable provides four Hirose 12P ports for connecting cameras, labeled CAM1 through CAM4. See *Options for Connecting Cameras* on page 66 for a description of the available breakout cables.

See the *Supported Cameras* document shipped with your Cognex software package for the most current list of supported cameras and cables. The location of this document is described in *Camera Cables for Supported Cameras* on page 71.

Connecting the Teli CS8541D and Sony DXC-390 cameras are exceptions. The cables for these cameras connect directly to the frame grabber's DB-26F camera port. You can connect only one Teli CS8541D or Sony DXC-390 to an MVS-8500 series frame grabber.

**Caution**

*The MVS-8500 series does not support hot plugging of cameras. Before you attach or detach a camera, be sure the PC's power is fully off. Attaching equipment to an MVS-8500 series frame grabber with the power on can result in electrical damage.*



## Connecting Parallel I/O Devices

The MVS-8500 series supports the connection of trigger and strobe devices, as well as general use I/O devices such as status LEDs, part reject switches, and so on. All MVS-8500 series frame grabbers *except for the MVS-8500Le* provide sixteen bidirectional TTL lines that can be controlled by Cognex software. The MVS-8500Le provides 8 lines. When used with the Cognex opto-isolated I/O module, all lines can be optically isolated.

Software commands in your vision processing application determine whether a bidirectional line is enabled for input or output. Each bidirectional line is independently controlled; any line can be either input or output.

On the MVS-8504, MVS-8514, MVS-8504e, and MVS-8514e, four of the lines can be configured as hardware trigger lines, and four can be configured as hardware strobe control lines. Software commands in your vision processing application determine whether the dedicated trigger or strobe feature of these lines is enabled.

Table 6 summarizes the cable and hookup requirements of the parallel I/O device connection options.

|                                   | Cognex cable | Connects to ...   | Then to ... |
|-----------------------------------|--------------|---|-------------|
| <b>Opto Option</b>                | 300-0389     | Opto-isolated I/O module, P/N 800-5712-3  |             |
| <b>TTL Option</b>                 | 300-0390     | Pass-through TTL I/O module, P/N 800-5818-1   | I/O devices |
| <b>Half Opto, Half TTL Option</b> | 300-0399     | One branch terminates in a 10-pin terminal strip. The other branch connects to the Opto-isolated I/O module, P/N 800-5712-3 |             |

Table 6. I/O connection option cables and equipment

### Caution

*The MVS-8500 series does not support hot plugging of I/O devices. Before you attach I/O devices, be sure the PC's power is fully off. Attaching equipment to an MVS-8500 series frame grabber with the power on can result in electrical damage.*

## Connecting TTL I/O Devices

Figure 10 illustrates the connection of parallel I/O devices to an MVS-8500 series frame grabber using the TTL option.

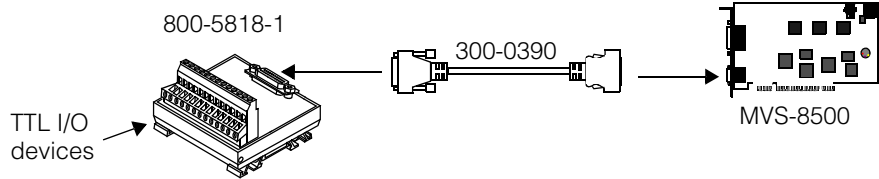

Figure 10. TTL connection option

The Cognex TTL I/O module is described in more detail in *TTL I/O Connection Module* on page 78.

To connect TTL devices to an MVS-8500 series frame grabber, follow these steps:

1. Make sure all parallel I/O devices and the PC hosting the frame grabber are powered off.
2. Connect Cognex cable 300-0390 to the MDR20 port on the faceplate of the frame grabber.
3. Connect the other end of the cable to the DB-25 connector on the TTL I/O module.
4. Attach the TTL I/O module to a convenient surface. It is configured for standard #3 DIN rail mounting.
5. Connect wires from I/O devices to screw terminals on the TTL I/O module, using the pinout in Table 24 on page 81 as a guideline.

See *Line Numbering* on page 75 for information on mapping the signal names in the pinout table to the software commands that you will use to enable, disable, set, and toggle each I/O line.

## Connecting I/O Devices with All Opto-Isolation

Figure 11 illustrates the connection of parallel I/O devices to an MVS-8500 series frame grabber using the all opto-isolated option.

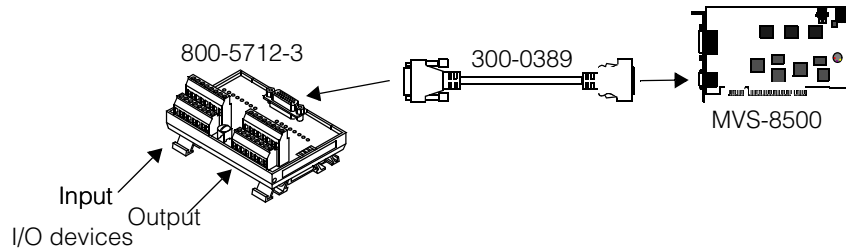

Figure 11. All opto-isolated connection option

For the all opto-isolated connection option, use cable 300-0389 to connect your frame grabber to the Cognex opto-isolated I/O module, P/N 800-5712-3. The opto-isolated I/O module takes the TTL signals from the frame grabber and passes them through optical isolation circuitry, splitting each TTL bidirectional line into a plus and minus pair of either input or output lines. You then connect parallel I/O devices to screw terminals on the external I/O module. The Cognex opto-isolated I/O module is described in more detail in *Opto-Isolated I/O Connection Module* on page 83.

To connect parallel I/O devices to an MVS-8500 series frame grabber with all optical isolation, follow these steps:

1. Make sure all parallel I/O devices and the PC hosting the frame grabber are powered off.
2. Connect Cognex cable 300-0389 to the MDR20 port on the faceplate of the frame grabber.
3. Connect the other end of cable 300-0389 to the DB-26F port labeled "Vision Processor" on the opto-isolated I/O module.
4. Attach the opto-isolated I/O module to a convenient surface. It is configured for standard #3 DIN rail mounting.
5. Connect a ground wire from the opto-isolated I/O module's screw terminal labeled "Ground" to a ground point.

### Caution

*The opto-isolated I/O module must have the same ground potential as the chassis of the PC containing the frame grabber. Any difference in potential can damage the equipment. If you connect a ground wire to the I/O module ground screw, then that ground must have the same potential as the frame grabber host's ground.*

6. Connect wires from your I/O input devices, including trigger devices, to the plus and minus terminals of the input block of the external I/O module. Use the pin numbering in Table 28 on page 94 as a guideline.

Notice that after opto-isolation of the TTL signal from the MVS-8500 series frame grabber, the connections listed in Table 28 are for inputs only, and are no longer bidirectional.

7. Connect wires from your I/O output devices, including strobes, to the plus and minus terminals of the output block of the external I/O module. Use the pin numbering in Table 30 on page 96 as a guideline.

Notice that after opto-isolation of the TTL signal from the MVS-8500 series frame grabber, the connections listed in Table 30 are for outputs only, and are no longer bidirectional.

See *Line Numbering* on page 75 for information on mapping the signal names in the pinout tables to the software commands that you will use to enable, disable, set, and toggle each I/O line.

## Connecting I/O Devices with Partial Opto-Isolation

Figure 12 illustrates the connection of parallel I/O devices to an MVS-8500 series frame grabber using the half opto-isolated, half TTL option.

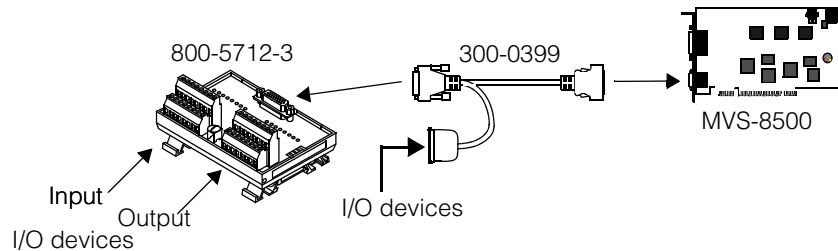

Figure 12. Half opto-isolated, half TTL connection option

With this option, eight of the frame grabber's parallel I/O lines are opto-isolated through the opto-isolated connection module, while the other eight lines are brought out to a Phoenix 10-pin terminal strip for direct connection as TTL lines. The four I/O lines that can be enabled as trigger lines are on the Phoenix connector, while the four lines that can be enabled as strobe lines are on the opto-isolated module.

To connect parallel I/O devices to an MVS-8500 series frame grabber with half optical isolation, half TTL, follow these steps:

1. Make sure all parallel I/O devices and the PC hosting the frame grabber are powered off.
2. Connect Cognex cable 300-0399 to the MDR20 port on the faceplate of the frame grabber.
3. Connect the DB-26M branch of cable 300-0399 to the DB-26F port labeled "Vision Processor" on the opto-isolated I/O module.
4. Attach the opto-isolated I/O module to a convenient surface. It is configured for standard #3 DIN rail mounting.
5. Connect a ground wire from the opto-isolated I/O module's screw terminal labeled "Ground" to a ground point.

**Caution**

*The opto-isolated I/O module must have the same ground potential as the chassis of the PC containing the frame grabber. Any difference in potential can damage the equipment. If you connect a ground wire to the I/O module ground screw, then that ground must have the same potential as the frame grabber host's ground.*

6. Connect wires from your I/O input devices to the plus and minus terminals of the input block of the opto-isolation I/O module. Use the pin numbering in Table 29 on page 95 as a guideline.

Notice that after opto-isolation of the TTL signal from the frame grabber, the connections listed in Table 29 are for inputs only, and are no longer bidirectional.

7. Connect wires from your I/O output devices, including strobes, to the plus and minus terminals of the output block of the opto-isolation I/O module. Use the pin numbering in Table 31 on page 97 as a guideline.

Notice that after opto-isolation of the TTL signal from the frame grabber, the connections listed in Table 31 are for outputs only, and are no longer bidirectional.

8. Connect wires from your TTL devices, including triggers, to the screw terminals on the 10-pin Phoenix terminal strip of cable 300-0399. Use the pin numbering in Table 26 on page 86 as a guideline.

See *Line Numbering* on page 75 for information on mapping the signal names in the pinout tables to the software commands that you will use to enable, disable, set, and toggle each I/O line.

**NOTES**

---

# MVS-8500 Series Hardware

# 2

This chapter describes Cognex MVS-8500 series frame grabber hardware and contains the following sections:

- *MVS-8500 Series Components* on page 48 describes the components that make up the MVS-8500 series.
- *Mechanical Specifications* on page 54 provides a physical description of the MVS-8500 series, including information about mechanical layout, environmental requirements, and safety standards.
- *Electrical Specifications* on page 60 describes the electrical interface to the MVS-8500 series, including power requirements, connector pinouts, and circuit descriptions.

## Note on Terminology

Throughout this manual:

- The terms ***MVS-8501***, ***MVS-8511***, ***MVS-8504***, and ***MVS-8514*** are used when discussing features specific to frame grabbers that plug into the PCI bus. The term ***MVS-8500/8510*** refers all PCI-bus boards.
- The terms ***MVS-8500Le***, ***MVS-8511e***, ***MVS-8504e***, and ***MVS-8514e*** are used when discussing features specific to frame grabbers that plug into the PCI bus. The term ***MVS-8500e/8510e*** refers all PCI Express-bus boards.
- The term ***MVS-8500 series frame grabber*** is used when discussing features common to all of the boards described in this manual.
- ***PCI*** refers to 32-bit PCI card slots, while PCI-X refers to 64-bit (extended) PCI card slots.
- ***PCIe*** refers to the PCI Express bus.
- Frame grabber names are sometimes abbreviated, dropping the MVS- prefix. For example, ***8500***, ***8504***, ***8514e*** or ***8504e***.

# MVS-8500 Series Components

This section describes MVS-8500 series frame grabbers and their components.

## PCI Bus Interface

The PCI bus interface of the MVS-8500/MVS-8510 is a universal voltage, 32-bit, 33/66 MHz interface that conforms to the PCI 2.3 standard.

The MVS-8504 and MVS-8514 models operate at 66 MHz, when placed in a PCI or PCI-X slot that supports 66 MHz operation, with no 33 MHz PCI boards on the same bus.

The MVS-8504 and MVS-8514 models operate at 33 MHz when placed in a standard 32-bit, 33 MHz PCI or PCI-X slot.

The MVS-8501 and MVS-8511 models operate at 33 MHz in all PCI or PCI-X slots.

## PCI Express Bus Interface

The MVS-8500e/MVS-8510e has an x1 PCI Express bus interface. PCI Express card slots come in four sizes: x1, x4, x8 and x16 as shown in Figure 3 on page 16. The MVS-8500e/MVS-8510e can be used in any PCI Express slot.

## Video Acquisition Interface

The video acquisition interface on the MVS-8500 series has the following characteristics:

- Supports up to four high speed cameras.
- Supports progressive scan cameras
- Supports interlaced cameras
- Supports external sync on the composite sync line (EIA RS-170 and CCIR formats only)
- Supports master-slave image acquisition: one master with up to three slaves, or two masters with one slave each

**Note** The MVS-8501, MVS-8511, MVS-8500Le, and MVS-8511e do not support master-slave acquisition.

- Each of the four camera ports incorporates an anti-aliasing filter
- Gain and offset control is software programmable
- Provides an external clamping circuit for each video channel



- Supports up to two camera control lines per camera port for electronic shutter, rapid reset, and other camera control

## Model Differences

There are eight models in the MVS-8500 series. Table 7 distinguishes the features of these eight models.

| Feature                              | PCI bus  |   | PCI Express Bus |           |                        |
|--------------------------------------|--|---|-----------------|-----------|------------------------|
|                                      | MVS-8501<br>MVS-8511   | MVS-8504<br>MVS-8514  | MVS-8500Le      | MVS-8511e | MVS-8504e<br>MVS-8514e |
| Bus interface                        | PCI Universal 32/64-bit, 33/66 MHz   |   | PCI Express, x1 |           |                        |
| Bus interface options                | 33 MHz operation in both 32-bit (short) PCI slots and 64-bit (long) PCI and PCI-X slots. | 66 MHz operation in 64-bit (long) PCI slots or PCI-X slots.<br><br>33 MHz operation in standard 32-bit (short) PCI slots (board extends past end of slot) | Any PCIe slot.  |           |                        |
| Cameras connected at same time       | 1 to 4   |   | 1 or 2          | 1 to 4    | 1 to 4                 |
| Asynchronous image acquisitions      | 1  | 1 to 4  | 1               | 1         | 1 to 4                 |
| Onboard video multiplexer            | Yes  | No  | Yes             | Yes       | No                     |
| Onboard video timing generators      | 1  | 4   | 1               | 1         | 4                      |
| Onboard analog-to-digital converters | 1  | 4   | 1               | 1         | 4                      |

Table 7. MVS-8500 series model differences

| <b>Feature</b>  | <b>PCI bus</b>                                   |                                 | <b>PCI Express Bus</b>         |                                |                                   |
|---|--|---------------------------------|--------------------------------|--------------------------------|-----------------------------------|
|   | <b>MVS-8501<br/>MVS-8511</b>                     | <b>MVS-8504<br/>MVS-8514</b>    | <b>MVS-8500Le</b>              | <b>MVS-8511e</b>               | <b>MVS-8504e<br/>MVS-8514e</b>    |
| Maximum recommended pixel clock                           | 40 MHz (MVS-8501/8504)<br>50 MHz (MVS-8511/8514) |                                 | 50 MHz                         |                                |                                   |
| Onboard SDRAM for FIFO buffer                             | 8 MB   | 16 MB                           | 8 MB                           | 8 MB                           | 16 MB                             |
| Supports master-slave image acquisition                   | no   | yes                             | no                             | no                             | yes                               |
| Supports RGB color cameras                                | no   | yes                             | no                             | no                             | yes                               |
| Supports dual-tap cameras                                 | no   | yes (MVS-8504)<br>no (MVS-8514) | no                             | no                             | yes (MVS-8504e)<br>no (MVS-8514e) |
| Number of bidirectional parallel I/O lines                | 16   | 16                              | 8                              | 16                             | 16                                |
| Parallel I/O lines configurable as hardware trigger lines | 1  | 4                               | 1                              | 1                              | 4                                 |
| Parallel I/O lines configurable as hardware strobe lines  | 1  | 4                               | 1                              | 1                              | 4                                 |
| Syncs to camera's HD/VD output                            | Camera 1 only                                    | All 4 cameras                   | Camera 1 only                  | Camera 1 only                  | All 4 cameras                     |
| Syncs to camera's composite video                         | All 4 cameras, but switching delay               | All 4 cameras                   | 2 cameras, but switching delay | 4 cameras, but switching delay | All 4 cameras                     |

*Table 7. MVS-8500 series model differences*

**Note** Your Cognex software package may only support a subset of the hardware video acquisition features. Consult your software's *Getting Started* manual or *Release Notes* for information on your software's support for MVS-8500 series hardware features.

## MVS-8500 Series Revision History

This section describes the revision history of the MVS-8500 series.

### MVS-8501, MVS-8511, MVS-8504, and MVS-8514

The PCI-bus version of the MVS-8500 series have been released in the versions shown in Table 8.

| <b>Board type</b> | <b>Circuit board part (etched on board)</b> | <b>MVS-8501 part numbers</b>             | <b>MVS-8504 part numbers</b>             |
|-------------------|---|--|--|
| <b>0200</b>       | 203-0200-Rn                                 | 801-8501-01                              | 801-8504-01,<br>801-8504-02              |
| <b>0236</b>       | 203-0236-Rn                                 | 801-8501-10,<br>801-8501-11,<br>or later | 801-8504-10,<br>801-8504-11,<br>or later |
| <b>3094</b>       | 203-3094-Rn                                 | 801-8511-10<br>or later                  | 801-8514-10<br>or later                  |

Table 8. Version differences for PCI-bus boards

### Early MVS-8504 Limitations (0200 Board Type)

The following MVS-8504 features are *not* supported on the earliest version of the MVS-8504, with circuit board part 203-0200-RA.

- Master-slave image acquisition
- Syncing to the camera's composite video
- Syncing to the camera's HD/VD output
- Dual-tap cameras

No MVS-8501 was released on the 203-0200-RA circuit board, so these limitations apply only to the early MVS-8504.

These features *are* supported on all subsequent revisions of the MVS-8504 and MVS-8514.

**MVS-8501 and MVS-8504 Redesign (0236 Board Type)**

MVS-8500 versions with circuit board type 0236 have part number 203-0236-Rn etched on the circuit board near one of the board edges. The 0236 versions are based on a redesigned circuit board. They are identical to their predecessors in form, fit, and function, but with lower power consumption.

**MVS-8511 and MVS-8514 Introduction (3094 Board Type)**

The MVS-8511 and MVS-8514 with circuit board type 3094 superseded the existing MVS-8501 and MVS-8504 boards. The 3094 featured a new A-to-D converter.

**MVS-8500Le, MVS-8511e, MVS-8504e, and MVS-8514e**

The PCI Express-bus version of the MVS-8500 series have been released in the versions shown in Table 9.

| <b>Board type</b> | <b>Circuit board part (etched on board)</b> | <b>MVS-8500Le or MVS-8511e part numbers</b> | <b>MVS-8504e or MVS-8514e part numbers</b> |
|-------------------|---|---|--|
| <b>3004</b>       | 203-3004-Rn                                 | 801-9002-01 or later                        | 801-9001-01 or later                       |
| <b>3095</b>       | 203-3095-Rn                                 | 801-9004-01 or later                        | 801-9003-01 or later                       |

*Table 9. Version differences for PCI Express-bus boards*

**MVS-8511e and MVS-8514e Introduction (3095 Board Type)**

The MVS-8511e and MVS-8514e with circuit board type 3095 superseded the existing MVS-8500Le and MVS-8504e boards. The 3095 board type featured a new A-to-D converter.

**Parallel I/O**

MVS-8500 series frame grabbers communicate with devices such as strobes, triggers, sensors, LEDs, and programmable controllers over parallel signal interface lines.

An MDR20 connector on the frame grabber faceplate provides sixteen programmable bidirectional TTL lines. Each bidirectional line can be set as an input or output line independently of the other lines.

On the MVS-8504, MVS-8514, MVS-8504e, and MVS-8514e four of the sixteen lines can be software-configured as hardware trigger lines, and four lines can be configured as strobe control lines, one per camera.

On the MVS-8501, MVS-8511, MVS-8500Le, and MVS-8511e one line can be configured as the trigger line for the active camera, and one line can be configured as the strobe line for the active camera.

Cognex provides cables to connect the MDR20 connector to one of:

- A pass-through TTL breakout adapter (cable 300-0390)
- An opto-isolated breakout adapter (cable 300-0389)
- Half the signals to the opto-isolated adapter and half to a screw terminal strip (cable 300-0399)

The MVS-8500 series frame grabbers support immediate mode triggering, which minimizes the external trigger to strobe/shutter latency (to  $\leq 2$  microseconds), when performing image capture of fast moving objects using electronically shuttered cameras.

## Image Acquisition and Video Output

MVS-8500 series image output is passed through the PCI bus or PCIe bus to an AGP or PCIe video display adapter under the control of the host PC's operating system. These frame grabbers provide the following features to support display of video images:

- DMA directly to video memory of the display adapter
- Color format conversion for 16-bit and 32-bit display formats

# Mechanical Specifications

This section describes the mechanical layout, connectors, environmental requirements, and shipment packaging for the MVS-8500 series frame grabbers.

## MVS-8501 and MVS-8504 Layout

The MVS-8501 and MVS-8504 are short length PCI cards, measuring 6.6 x 4.2 inches (168 x 107 mm), and occupying a single PCI bus slot. Figure 13 shows the connectors and LEDs on the board.

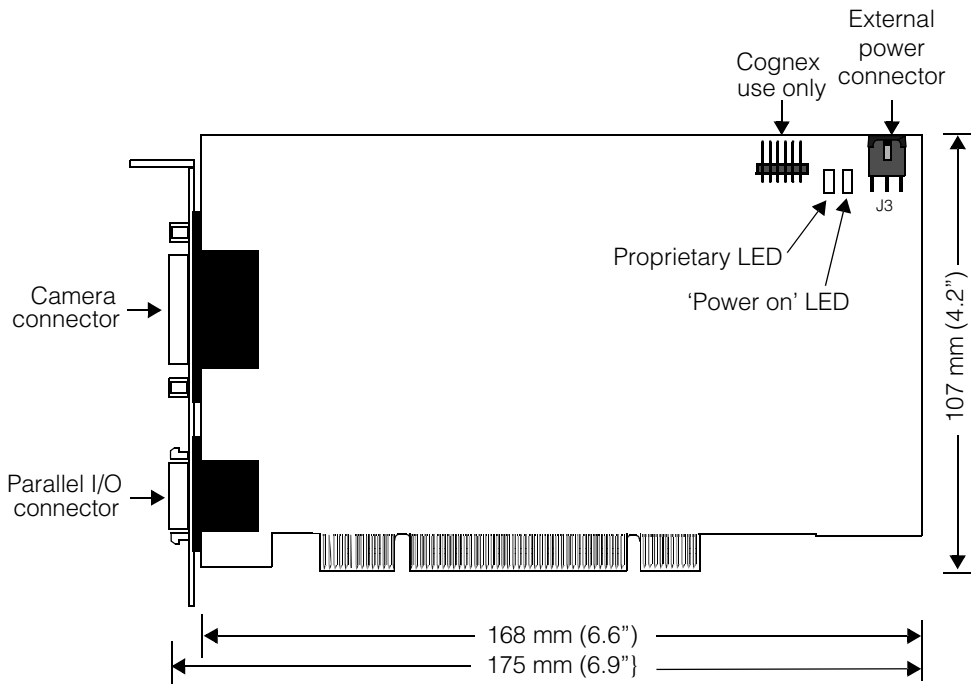

Figure 13. MVS-8501 and MVS-8504 component location

## MVS-8511 and MVS-8514 Layout

The MVS-8511 and MVS-8514 are short length PCI cards, measuring 6.6 x 4.2 inches (168 x 107 mm), and occupying a single PCI bus slot. Figure 13 shows the connectors and LEDs on the board. Separate power LEDs are supplied to indicate the presence of 3.3V, 12V, and 5V input power.

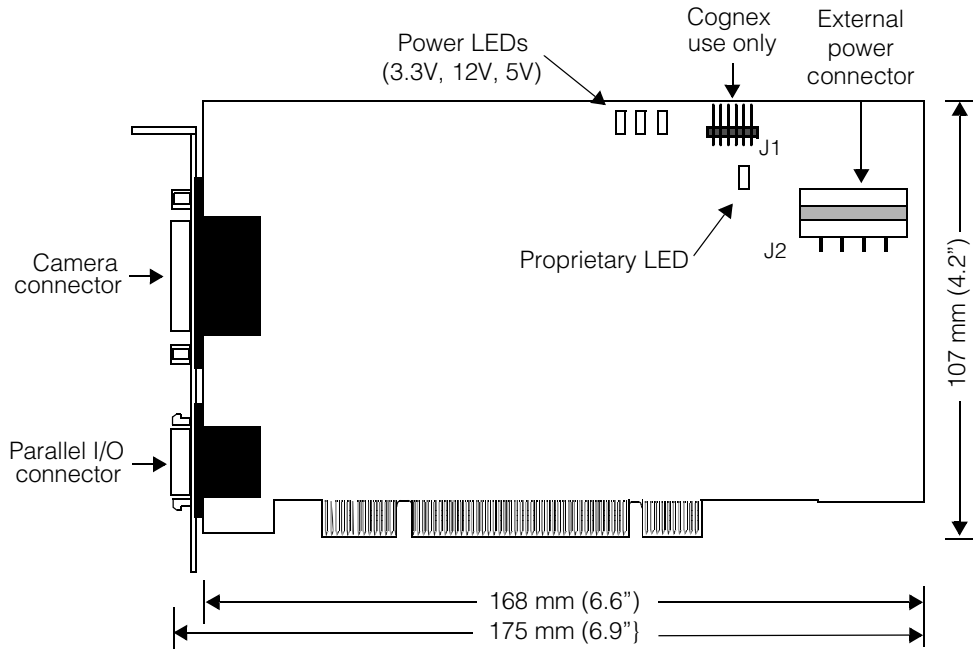

Figure 14. MVS-8511 and MVS-8514 component location

## MVS-8500Le, MVS-8511e, MVS-8504e, and MVS-8514e Layout

The MVS-8500Le, MVS-8511e, MVS-8504e, and MVS-8514e are short length PCIe cards, measuring 6.6 x 4.2 inches (168 x 107 mm), and occupying a single x1 PCIe bus slot. Figure 15 shows the connectors and LEDs on the board. Separate power LEDs are supplied to indicate the presence of 3.3V, 12V, and 5V input power.

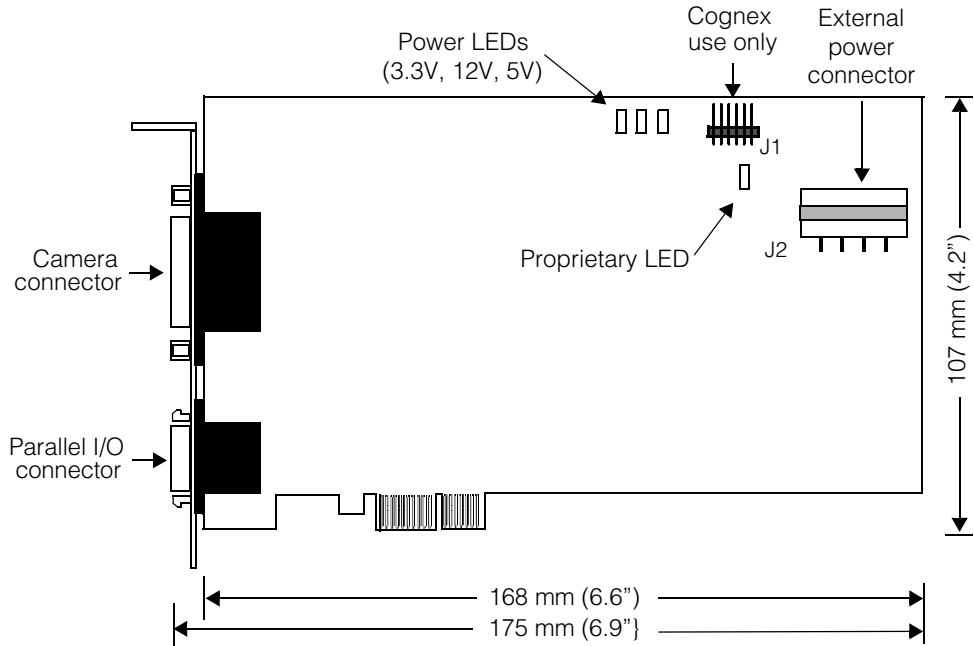

Figure 15. MVS-8500Le, MVS-8511e, MVS-8504e, and MVS-8514e component location



## Connector Summary

MVS-8500 series frame grabbers have the following connectors on the faceplate:

- DB-26 female connector, Amp part number 748481-5, for connecting cameras by means of a breakout cable. This port connects to a cable with an HD-DB26M connector, Amp part number 748469-1 or equivalent. The pin numbering and pinout of the camera connector are described in *Camera Connector* on page 63.
- MDR20 female connector, 3M part number D10220-55H3VC, for connecting triggers, strobes, and parallel I/O devices. Connects to a cable with a 20-pin MDR connector, 3M part number 10120-600EC, with 10320-A200-00 backshell kit, or equivalents. The pin numbering and pinout of this port are described in *Pinout of Parallel I/O Connector* on page 74.

MVS-8500 series frame grabbers have one user-accessible jack on the circuit board: an external power connector that you connect to the PC power supply to provide +12 V power to your cameras and +5 V power for the frame grabber itself (except for the MVS-8501 and MVS-8504, which do not require external +5V power).

The power connector is located in the upper right corner of the circuit board as you hold the board with faceplate to the left. The power connectors are different depending on the board type.

- The MVS-8501 and MVS-8504 power connector is labeled J3 and is a three-pin header, Berg part number 78203-103. Cognex cable 300-0391, or equivalent, plugs into J3. This power cable connects to one of the host PC's disk drive power supply connectors using Molex part 50-57-9403 with appropriate terminal pins. See Figure 4 on page 24.
- The MVS-8511, MVS-8514, MVS-8500Le, MVS-8511e, MVS-8504e, and MVS-8514e power connector is labeled J2 and is a standard Molex connector used in PC disk drives. You can plug any available PC power supply cable into this jack. See Figure 4 on page 24.

Figure 16 shows the appearance and pin assignments of the two external power connectors. See the section *Power Requirements* on page 60 for more information.

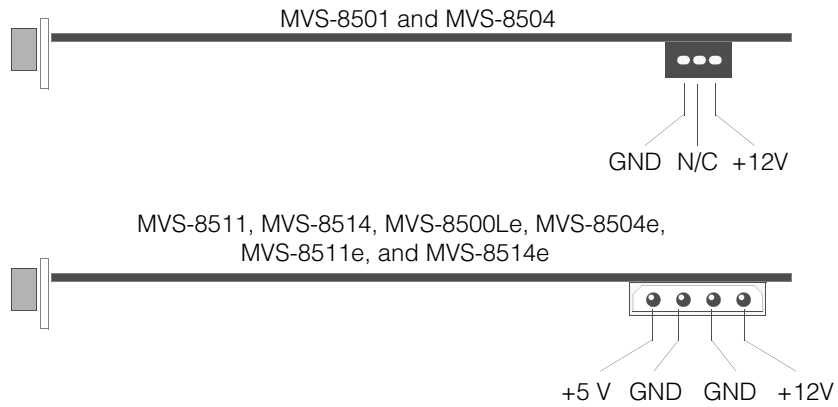

Figure 16. MVS-8500 series external power connectors

## Environmental Requirements

Table 10 lists the environmental requirements for the MVS-8500 series. These specifications are for the environment inside the PC where the frame grabber board is installed.

|                                     | Operating Conditions | Storage Conditions |
|-------------------------------------|----------------------|--------------------|
| <b>Temperature</b>                  | 0° to 50° C          | -40° to 65° C      |
| <b>Humidity</b><br>(non-condensing) | 10% to 90%           | 10% to 90%         |

Table 10. Environmental requirements

## Shipping

All MVS-8500 series frame grabbers are shipped in protective packaging and antistatic bags. Save all packing materials in case you need to re-ship the frame grabber.

# Standards Compliance

The MVS-8500 series frame grabbers meet the following worldwide standards for safety, electromagnetic compatibility, and electrostatic sensitivity.

## International

Compliance with the following electromagnetic emissions standards:

- United States Code of Federal Regulations Part 15: Federal Communications Commission Class A radio frequency emissions standard
- European Union emissions standard EN55022: 2006/A1:2007, EN 61000-3-2:2006, and EN 61000-3-3:1995 + A1:2001, EN55024:1998/A1:2001/A2:2003.
- Japanese VCCI standard
- Australia and New Zealand CISPR 22:2006
- Canadian ICES-003
- Korea KCC No. 2009-27 November 05, 2009 for emissions and immunity, Class A.

| Class    | User's Guide   |
|----------|--|
| <b>A</b> | Please note that this equipment has obtained EMC registration for commercial use. In the event that it has been mistakenly sold or purchased, please exchange it for equipment certified for home use. |
| <b>B</b> | As this equipment has obtained EMC registration for house hold use, it can be used in any area including residential area  |

# Electrical Specifications

This section describes the electrical specifications of the MVS-8500 series, including power requirements and signal descriptions.

## Power Requirements

The MVS-8501 and MVS-8504 draw +5V power from the PCI bus while the MVS-8511 and MVS-8514 draw +3.3V and +5V power from the PCI bus. All MVS-8500e/8510e frame grabbers draw +3.3V and +12V power from the PCIe bus and +5V power from the external power connector. The maximum current draw occurs during board power-up.

On the MVS-8500 series, camera power is drawn from an external power connector and is not pulled through the PCI bus. For all boards, an external power adapter must connect to the frame grabber board through a power jack. (See *Connector Summary* on page 57).

For an alternative +12V power source for the cameras, you can provide +12V camera power through one of the breakout cables, as described in *Monochrome Breakout Cable with Power Input* on page 67.

### Note

If you are using the MVS-8500e/8510e, you must connect +5V power to the external power connector on the board (J2) even if you connect +12V power to the breakout cable.

The power requirements and power consumption specifications are different for the 0200 and 0236 circuit board versions of the MVS-8500. To determine the version of your MVS-8500 frame grabber, see *MVS-8500 Series Revision History* on page 51.

The voltage numbers in the following tables have a tolerance of  $\pm 5\%$ .

## MVS-8501 and MVS-8504 0200 Version Power Requirements

Table 11 shows the maximum voltage draws from the 0200 circuit board version of the MVS-8500 series.

| Voltage | MVS-8501 | MVS-8504 |
|---------|----------|----------|
| +5 V    | 2.4 A    | 4.2 A    |
| +12 V   | 0.1 A    | 0.2 A    |
| -12 V   | 0.1 A    | 0.2 A    |

Table 11. MVS-8500 series (0200 version) maximum voltage draws

Maximum power consumption for the 0200 board version is approximately:

- MVS-8501: 14.4 watts
- MVS-8504: 25.8 watts

## MVS-8501 and MVS-8504 0236 Version Power Requirements

Table 12 shows the maximum voltage draws from the 0236 circuit board version of the MVS-8500 series. This version does not draw 12 V power from the PCI bus.

| Voltage | Source                   | MVS-8501    | MVS-8504 |
|---------|--------------------------|-------------|----------|
| +5 V    | PCI Bus                  | 2.4 A       | 3.8 A    |
| +12 V   | External power connector | camera only |          |

Table 12. MVS-8500 series (0236 version) maximum voltage draws

Maximum power consumption for the 0236 board version is approximately:

- MVS-8501: 12.0 watts
- MVS-8504: 19.0 watts

## MVS-8511 and MVS-8514 3094 Version Power Requirements

Table 13 shows the maximum voltage draws from the 3094 circuit board version of the MVS-8500. This version does not draw 12 V power from the PCI bus.

| Voltage | Source                   | MVS-8511    | MVS-8514 |
|---------|--------------------------|-------------|----------|
| +3.3V   | PCI Bus                  | 0.5 A       |          |
| +5 V    | PCI Bus                  | 1.3 A       |          |
| +5 V    | External power connector | <50 mA      |          |
| +12 V   | External power connector | camera only |          |

Table 13. MVS-8500 series (3094 version) maximum voltage draws

Maximum power consumption for the 3094 board version is approximately 8.0 watts for both MVS-8511 and MVS-8514.

## MVS-8500Le and MVS-8504e 3004 Version Power Requirements

Table 14 shows the maximum voltage draws from the 3004 circuit board version of the MVS-8500 series.

| Voltage | Source                   | MVS-8500Le | MVS-8504e   |
|---------|--------------------------|------------|-------------|
| +3.3 V  | PCIe Bus                 | 2.0 A      | 3.0 A       |
| +12 V   | PCIe Bus                 | 0.25 A     | 0.5 A       |
| +5 V    | External power connector | 0.25 A     | 0.5 A       |
| +12 V   | External power connector |            | camera only |

Table 14. MVS-8500e series (3094 version) maximum voltage draws

Maximum power consumption for the MVS-8500e is approximately:

- MVS-8500Le: 11.0 watts
- MVS-8504e: 19.0 watts

## MVS-8511e and MVS-8514e 3095 Version Power Requirements

Table 15 shows the maximum voltage draws from the 3095 circuit board version of the MVS-8500 series.

| Voltage | Source                   | MVS-8511e | MVS-8514e   |
|---------|--------------------------|-----------|-------------|
| +3.3 V  | PCIe Bus                 | 2.0 A     | 2.0 A       |
| +12 V   | PCIe Bus                 | 0.30 A    | 0.30 A      |
| +5 V    | External power connector | 0.20 A    | 0.20 A      |
| +12 V   | External power connector |           | camera only |

Table 15. MVS-8510e series (3095 version) maximum voltage draws

Maximum power consumption for the 3095 board version is approximately 11.0 watts for both MVS-8511e and MVS-8514e.

## Fuses

There are no user-replaceable fuses on MVS-8500 series frame grabbers.

MVS-8500 series boards have the following lines protected by PolySwitch resettable fuses:

- Each camera input channel is protected at 500 mA per channel.
- Each camera's HD, VD, CTRL1, and CTRL2 lines are individually protected at 100 mA each.
- The +5 V output lines of the parallel I/O connector (pins 1 and 11) are together protected at a minimum of 500 mA. The fuse nominal rating is 750 mA.
- The external +12 V input lines from the external power connector (J3 on the MVS-8501 and MVS-8504; J2 on the MVS-8511, MVS-8514, MVS-8500Le, MVS-8511e, MVS-8504e, and MVS-8514e) are protected at a minimum of 1.0 A for camera channels 1 and 2, and 1.0 A for channels 3 and 4. The fuse nominal rating is up to 1.5 A each.

In the fuse list above, some entries show both a minimum and a nominal rating. In typical use, these fuses can pass up to the nominal rating, but their trip point is temperature dependent, and lowers as temperature rises. Under the operating condition temperatures shown in Table 10 on page 58, these fuses will always pass at least the minimum rating.

If an over voltage or over current condition occurs on one of the above listed lines, the PolySwitch fuse trips, opening the circuit. You only need to remove the device that caused the condition, correct the overcurrent condition, wait a few minutes for the PolySwitch circuitry to cool down, then plug the device back in. The fuse resets itself.

## Camera Connector

Cameras are attached to MVS-8500 series frame grabbers through its DB-26F camera connector, as described in *Options for Connecting Cameras* on page 66.

Pin numbering for the camera connector is shown in Figure 17. The orientation is looking straight into the connector with the frame grabber board held horizontally, facing the faceplate, with the MDR20 parallel I/O connector on the right of the DB-26 connector.

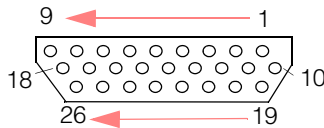

Figure 17. Pin numbering of camera connector

The pinout of the camera connector is shown in Table 16.

| Pin | Signal Name | Pin | Signal Name | Pin | Signal Name         |
|-----|-------------|-----|-------------|-----|---------------------|
| 1   | VIDEO-Cam3  | 10  | VDrive-Cam4 | 19  | CTRL1-Cam4          |
| 2   | GND         | 11  | HDrive-Cam4 | 20  | CTRL2-Cam4          |
| 3   | CTRL2-Cam3  | 12  | CTRL1-Cam3  | 21  | +12 V (Cam 3 and 4) |
| 4   | HDrive-Cam3 | 13  | VDrive-Cam3 | 22  | VIDEO-Cam4          |
| 5   | VIDEO-Cam2  | 14  | GND         | 23  | +12 V (Cam1 and 2)  |
| 6   | GND         | 15  | CTRL1-Cam2  | 24  | CTRL2-Cam1          |
| 7   | VDrive-Cam2 | 16  | CTRL2-Cam2  | 25  | HDrive-Cam1         |
| 8   | GND         | 17  | HDrive-Cam2 | 26  | VDrive-Cam1         |
| 9   | VIDEO-Cam1  | 18  | CTRL1-Cam1  |     |                     |

Table 16. Pinout for camera connector

## Analog Video Input Circuit

CAM VIDEO, the video input signal, is approximately 1 V peak to peak and is terminated with a 75 Ω resistor to ground. Each of the analog video signals connects to the frame grabber as shown in Figure 18.

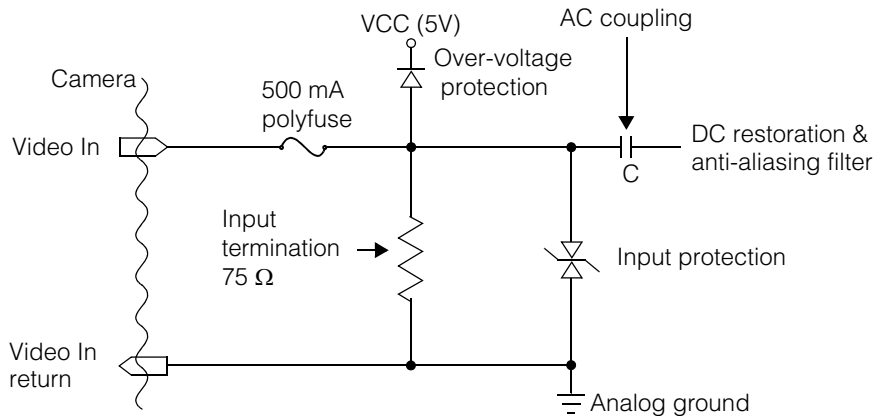

Figure 18. Analog video input circuit



The video signal is terminated with a  $75\ \Omega$  load and is AC-coupled into the video input section. The video signal is DC-restored internally and the anti-aliasing filter provides noise rejection for switching and random noise above the CAM VIDEO rate. Digitization of the input signal is relative to the black level during the blanking interval and is not affected by any DC offset that the camera may generate.

The ESD protection device provides static discharge protection to the circuitry.

Figure 19 shows the totem-pole or push-pull circuit used to drive the horizontal and vertical drive signals of the CVM:

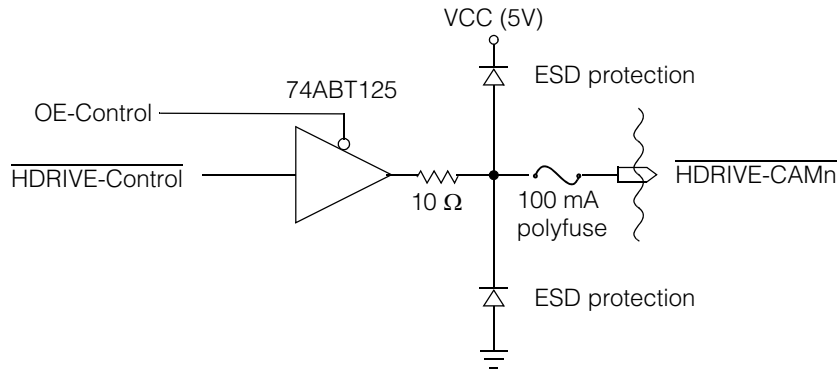

Figure 19. Analog camera control circuit

High-level and low-level outputs have TTL level characteristics guaranteed to drive a  $75\ \Omega$  terminated or high-impedance HDRIIVE or VDRIIVE camera input.

# Options for Connecting Cameras

Cognex cables to connect cameras to the MVS-8500 series are of two types:

- Cables that connect directly to the 26-pin camera port on the frame grabber faceplate
- Cables that terminate in Hirose HR10A connectors

To connect Hirose HR10A type camera cables to the MVS-8500 series, you must first connect a breakout cable. Table 17 describes the camera connection options for these cases.

|  | <b>+12V camera power input?</b> | <b>Cognex part number</b> | <b>Described in</b>  |
|--|---------------------------------|---------------------------|--|
| <b>Monochrome camera breakout cables, cameras only</b>   | No                              | 300-0232                  | <i>Monochrome Breakout Cables, Cameras Only</i> on page 66   |
|  |                                 | 300-9116                  |  |
| <b>Monochrome camera breakout cable with power input</b> | Yes, required                   | 300-0230                  | <i>Monochrome Breakout Cable with Power Input</i> on page 67 |
| <b>Color+Monochrome camera breakout cable</b>            | No                              | 300-0406                  | <i>Color+Monochrome Breakout Cable</i> on page 69            |

Table 17. Camera connection options

Cognex camera cables for use with the MVS-8500 series are discussed in *Camera Cables for Supported Cameras* on page 71.

## Monochrome Breakout Cables, Cameras Only

The MVS-8500 series frame grabbers support two camera-only breakout cables:

- A four-camera, camera-only breakout cable (Cognex part number 300-0232).
- A two-camera, camera-only breakout cable (Cognex part number 300-9116).

**Note**

The two-camera cable is intended for the MVS-8500Le, which only supports 2 cameras. You can use it with any other MVS-8500 series frame grabber, but it only provides support for cameras 1 and 2.

To attach the breakout cable, follow these steps:

1. With power off to your PC and cameras, plug the camera breakout cable into the DB-26F connector on the frame grabber faceplate. Secure the breakout cable to the connector.
2. Identify the appropriate Hirose camera cables for your cameras from the *Supported Cameras* document delivered with your Cognex software package, as described in *Camera Cables for Supported Cameras* on page 71.
3. For the first camera, connect one end of the camera's cable to the Hirose connector on the camera, labeled DC IN/SYNC, or VIDEO/DC IN, or similar wording. Connect the cable's other end to the breakout cable branch labeled CAM 1.
4. To connect additional cameras, use the appropriate camera cable to connect the Hirose connector on each camera to the next available Hirose connector on the camera breakout cable.

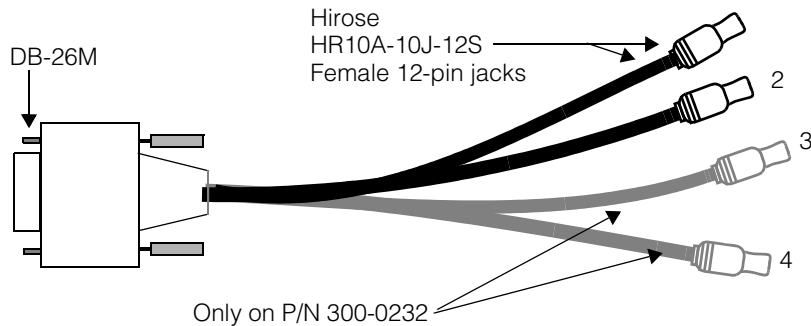

Figure 20. Camera-only breakout cables, PN 300-0232 and 300-9116

## Monochrome Breakout Cable with Power Input

The alternative breakout cable, Cognex part number 300-0230, provides four Hirose connector branches plus a fifth cable branch for camera power input. The fifth branch has a 5-pin female DIN connector that accepts an external power supply to provide the +12 V camera power.

**Note** You *must* connect a power supply to the cable when using this breakout cable.

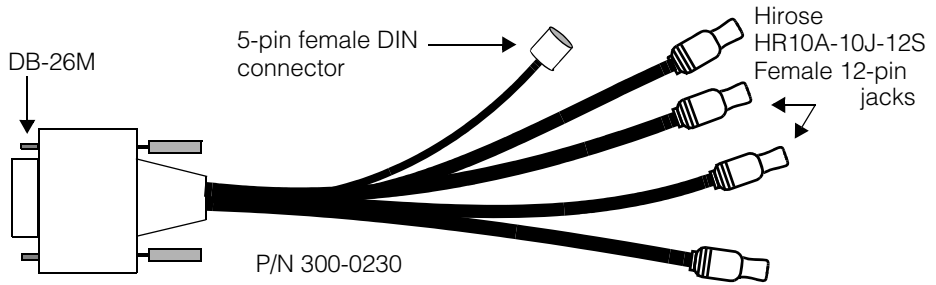

Figure 21. Camera breakout cable with power input, P/N 300-0230

Use Cognex power adapter 800-5728-1 with this cable, or an equivalent adapter that has the characteristics described in this section. The pin numbering for the 5-pin female DIN connector is shown in Figure 22, while the pinout for this connector is shown in Table 18.

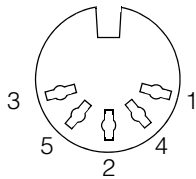

Figure 22. Pin numbering for DIN power connector on cable 300-0230

| Pin on DIN connector | Signal |
|----------------------|--------|
| 1                    | GND    |
| 2                    | NC     |
| 3                    | NC     |
| 4                    | NC     |
| 5                    | +12 V  |

Table 18. Pinout for power input DIN connector on cable 300-0230

**Note** Camera input power is not fused when using cable 300-0230.

## Choosing a Monochrome Breakout Cable

The camera-only breakout cable, 300-0232, can be used in the majority of cases, such as when connecting up to four Sony XC-HR50 cameras.

Use the power input breakout cable, 300-0230, when the rated power draw from all attached cameras exceeds the fuse limitations for the external power connector, as described in *Fuses* on page 62.

For example, if you are connecting two cameras that pull 750 mA each to camera ports 1 and 2, use the power input breakout cable and supply external camera power to the cable. This is because the combined draw of 1.5 A for camera channel 1+2 exceeds the suggested 1 A limit described in the *Fuses* section.

By contrast, if you connect one 750 mA camera to camera port 1 and a second 750 mA camera to camera port 3, you can use the camera-only breakout cable, since each camera pair (1+2 and 3+4) is within its 1 A limit.

## Color+Monochrome Breakout Cable

The color+monochrome breakout cable is Cognex part number 300-0406. To attach the breakout cable and cameras, follow these steps:

1. With power off to your PC and cameras, plug the camera breakout cable into the DB-26F connector on the frame grabber faceplate. Secure the breakout cable to the connector.
2. For the monochrome camera, use the appropriate camera cable for your camera as listed in the *Supported Cameras* document for your Cognex software package. (See *Camera Cables for Supported Cameras* on page 71.) Connect the monochrome camera's cable to the Hirose connector on the monochrome camera, and connect the other end of that cable to the breakout's Hirose HR-10 female jack. This connector is on the end of the 18-inch branch of the breakout cable.

- To connect the Sony DXC-390 color camera, connect the DB-9M connector from the cable to the RGB/SYNC connector on the camera. Then connect the Hirose HR-10 female plug to the DC IN/VBS OUT connector on the camera.

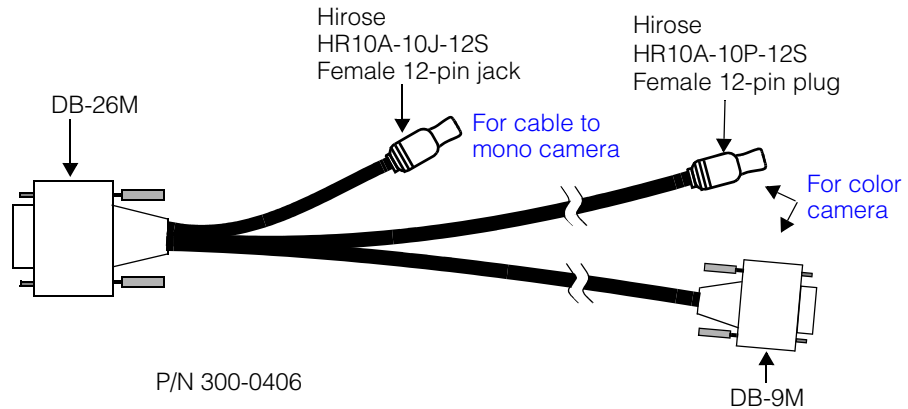

Figure 23. Color/monochrome breakout cable, P/N 300-0406

## Software Line Numbers

When using cable 300-0406, address the color camera as camera 0 in your Cognex software, and address the monochrome camera as camera 3.

## Hirose Connector Pinout

The pin numbering of the different types of Hirose HR10 connectors is explained in *Hirose HR10 Connector Description* on page 99.

Table 19 shows the pinout for all Hirose HR10 12-pin connectors, whether receptacle, plug, or jack, when used with monochrome analog video cameras.

| Pin | Signal       | Notes |
|-----|--------------|-------|
| 1   | Ground       |       |
| 2   | +12 VDC      |       |
| 3   | Video ground |       |
| 4   | Video signal |       |
| 5   | HD ground    |       |

Table 19. Hirose HR10 12-pin connector pinout

| Pin | Signal                       | Notes  |
|-----|------------------------------|--|
| 6   | HD (horizontal drive) signal |  |
| 7   | VD (vertical drive) signal   |  |
| 8   | Camera control 2             | Pins 8, 9, 10, and 11 might be used by different cameras for different purposes. The Cognex cable for each camera maps these pins correctly for that camera. |
| 9   | No connection                |  |
| 10  | Camera control 1             |  |
| 11  | No connection                | Pin 11 is defined as a second +12V line in some implementations, but the Cognex breakout cables do not pass +12V on this line.                               |
| 12  | VD ground                    |  |

Table 19. Hirose HR10 12-pin connector pinout

## Camera Cables for Supported Cameras

The cameras supported on MVS-8500 series frame grabbers, and the Cognex cables to use with each camera, are listed in the *Supported Cameras* document, which is included with the documentation for your Cognex software package.

For VisionPro, open VisionPro Help, then select the *Supported Cameras and Cables* entry in the help system menu.

For CVL, open the *CVL Supported Cameras* entry in the Cognex Documentation menu in the Windows Start -> Programs menu.

### **Caution**

*Cameras must be connected using the Cognex cables shown in the Supported Cameras table that accompanies your Cognex software package. Using non-Cognex camera cables could damage your vision processor, your camera, or both.*

## Triggers, Strobes, and Parallel I/O Connector

The parallel I/O connector provides a connection point for I/O devices such as triggers, strobes, part rejection switches, status LEDs, and other parallel I/O devices. Each bidirectional line can be software-configured as an input or output line, independently of the other lines.

MVS-8500 series frame grabbers (except for the MVS-8500Le) provide sixteen independent bidirectional TTL lines, of which eight lines can be configured to control hardware triggers and strobes. The MVS-8500Le only supports 8 lines.

The sixteen lines are arranged as follows:

- Lines 0 through 7 are general purpose bidirectional lines. (These lines are not available on the MVS-8500Le).
- The following lines can be software-enabled as hardware trigger lines:
  - For MVS-8504, MVS-8514, MVS-8504e, and MVS-8514e, lines 8, 10, 12, and 14, one per camera channel.
  - For MVS-8501, MVS-8511, MVS-8500Le, and MVS-8511e, line 8 for the currently active camera.
- The following lines can be software-enabled as hardware strobe control lines, one per camera channel.
  - For MVS-8504, MVS-8514, MVS-8504e, and MVS-8514e, lines 9, 11, 13, and 15, one per camera channel.
  - For MVS-8501, MVS-8511, MVS-8500Le, and MVS-8511e, line 9 for the currently active camera.
- If any of lines 8 through 15 are not used for dedicated trigger or strobe purposes, then that line is available for use as a general purpose bidirectional line.

This information is summarized in the following table:

| Lines   | PCI bus              |                      | PCI Express Bus |              |                        |
|---|----------------------|----------------------|-----------------|--------------|------------------------|
|   | MVS-8501<br>MVS-8511 | MVS-8504<br>MVS-8514 | MVS-8500Le      | MVS-8511e    | MVS-8504e<br>MVS-8514e |
| General purpose bidirectional lines only  | 0 - 7, 10-15         | 0-7                  | 10 - 15         | 0 - 7, 10-15 | 0-7                    |
| Can be software configured as hardware triggers, otherwise can be used as general purpose I/O lines         | 8                    | 8, 10, 12, 14        | 8               | 8            | 8, 10, 12, 14          |
| Can be software configured for hardware strobes control, otherwise can be used as general purpose I/O lines | 9                    | 9, 11, 13, 15        | 9               | 9            | 9, 11, 13, 15          |

Table 20. Triggers, Strobes and Parallel I/O Lines



## Connecting Devices

Do not connect I/O devices directly to the MDR20 connector. To connect parallel I/O devices, use one of the following cable options to connect to an external I/O module. Then connect wires from triggers, strobes, and other devices to screw terminals on the I/O module.

- **TTL.** To connect TTL devices, use Cognex cable 300-0390 to connect to the Cognex TTL I/O module, part number 800-5818-1. Connect wires from triggers, strobes, and other devices to screw terminals on the I/O module. This cable and module combination is described in *TTL I/O Connection Module* on page 78.
- **Opto-Isolated.** To optically isolate all sixteen I/O lines from connected I/O devices, use Cognex cable 300-0389 to connect to the Cognex opto-isolated I/O module, part number 800-5712-3. This cable and module combination is described in *Full Opto Cable from MVS-8500 Series to Opto I/O Module* on page 83.
- **Half Opto, Half TTL.** Using cable 300-0399, eight I/O lines are brought out to a Phoenix terminal strip for direct connection of device wires, while the other eight lines connect through a Y-branch to the Cognex opto-isolated I/O module, part number 800-5712-3. This cable and module combination is described in *Half Opto Cable from MVS-8500 Series to Opto I/O Module* on page 85.

Be aware of the following when using the opto-isolated I/O module:

- The bidirectionality of all lines is lost at the opto-isolated module. The lines are either input lines or output lines.
- The opto-isolation circuitry adds a small delay to the firing of strobe pulses and the recognition of triggers by the MVS-8500 and MVS-8500e, as described in *Opto-Isolated I/O Module Adds Conversion Delay* on page 90.

### **Caution**

*Turn off power to any connected I/O devices before powering an MVS-8500 series frame grabber on or off.*

## Pinout of Parallel I/O Connector

Parallel I/O devices are attached to an MVS-8500 series frame grabber through the front faceplate MDR20 connector. The pin numbering of the connector is shown in Figure 24. The orientation is looking straight into the connector with the frame grabber board held horizontally, facing the faceplate, with the DB-26 camera connector on the left of the MDR20 connector.

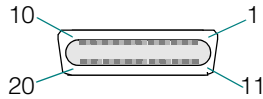

Figure 24. Pin numbering of parallel I/O connector

The pinout of the parallel I/O connector is shown in Table 21.

| SW line | Pin | Signal Name at power-on | Signal names, when strobe & trigger are enabled |                                   |                        |            |
|---------|-----|-------------------------|---|-----------------------------------|------------------------|------------|
|         |     |                         | MVS-8504<br>MVS-8514                            | MVS-8501<br>MVS-8511<br>MVS-8511e | MVS-8504e<br>MVS-8514e | MVS-8500Le |
|         | 1   | +5 V                    |   |                                   |                        |            |
| 0       | 2   | TTL_BI_0                | GP I/O 0  | GP I/O 0                          | GP I/O 0               | Not Used   |
| 2       | 3   | TTL_BI_2                | GP I/O 2  | GP I/O 2                          | GP I/O 2               | Not Used   |
| 4       | 4   | TTL_BI_4                | GP I/O 4  | GP I/O 4                          | GP I/O 4               | Not Used   |
| 6       | 5   | TTL_BI_6                | GP I/O 6  | GP I/O 6                          | GP I/O 6               | Not Used   |
|         | 6   | GND                     |   |                                   |                        |            |
| 8       | 7   | TTL_BI_8                | TRIG1   | TRIG                              | TRIG1                  | TRIG       |
| 10      | 8   | TTL_BI_10               | TRIG2   | GP I/O 10                         | TRIG2                  | GP I/O 10  |
| 12      | 9   | TTL_BI_12               | TRIG3   | GP I/O 12                         | TRIG3                  | GP I/O 12  |
| 14      | 10  | TTL_BI_14               | TRIG4   | GP I/O 14                         | TRIG4                  | GP I/O 14  |
|         | 11  | +5 V                    |   |                                   |                        |            |
| 1       | 12  | TTL_BI_1                | GP I/O 1  | GP I/O 1                          | GP I/O 1               | Not Used   |
| 3       | 13  | TTL_BI_3                | GP I/O 3  | GP I/O 3                          | GP I/O 3               | Not Used   |

Table 21. Pinout of the MVS-8500 series parallel I/O connector

| Signal names, when strobe & trigger are enabled |     |                         |                      |                                   |                        |            |
|---|-----|-------------------------|----------------------|-----------------------------------|------------------------|------------|
| SW line   | Pin | Signal Name at power-on | MVS-8500 Series      |                                   |                        |            |
|   |     |                         | MVS-8504<br>MVS-8514 | MVS-8501<br>MVS-8511<br>MVS-8511e | MVS-8504e<br>MVS-8514e | MVS-8500Le |
| 5   | 14  | TTL_BI_5                | GP I/O 5             | GP I/O 5                          | GP I/O 5               | Not Used   |
| 7   | 15  | TTL_BI_7                | GP I/O 7             | GP I/O 7                          | GP I/O 7               | Not Used   |
|   | 16  | GND                     |                      |                                   |                        |            |
| 9   | 17  | TTL_BI_9                | STROBE1              | STROBE                            | STROBE1                | STROBE     |
| 11  | 18  | TTL_BI_11               | STROBE2              | GP I/O 11                         | STROBE2                | GP I/O 11  |
| 13  | 19  | TTL_BI_13               | STROBE3              | GP I/O 13                         | STROBE3                | GP I/O 13  |
| 15  | 20  | TTL_BI_15               | STROBE4              | GP I/O 15                         | STROBE4                | GP I/O 15  |

Table 21. Pinout of the MVS-8500 series parallel I/O connector

## Line Numbering

The correspondence between trigger lines, strobe lines, and camera channels is one-to-one.

Cognex vision processing software generally counts parallel I/O lines starting with line zero. For the MVS-8500 series, the correspondence is one-to-one between software line numbers and signal name numbers, as shown in the `TTL_BI_n` signal names in Table 21. For example, the software command `enable(0)` would address the device connected to signal name `TTL_BI_0` (on pin 2). The command `enable(3)` would address the device connected to signal name `TTL_BI_3` (on pin 13), and so on.

Image acquisition can be software or hardware triggered. If hardware triggers are enabled on the MVS-8504, MVS-8514, MVS-8504e, or MVS-8514e, a pulse from a trigger device connected to the TRIG1 line initiates an image acquisition on the camera connected to camera channel 1. If strobes are enabled, a strobe connected to the STROBE1 line is fired. Likewise, if enabled, a trigger pulse on TRIG2 acquires an image on camera channel 2 and if enabled fires the strobe on STROBE2; and so on.

If hardware triggering is enabled on the MVS-8501, MVS-8511, MVS-8511e or MVS-8500Le, a pulse from a trigger device connected to the TRIG line initiates an image acquisition on the currently active camera, and if strobes are enabled, fires a strobe connected to the STROBE line. Cameras are made currently active with software commands.

To summarize:

- Trigger and strobe lines are numbered from 1, and correspond to camera port numbers on the MVS-8504, MVS-8514, MVS-8504e, or MVS-8514e.
- Bidirectional parallel I/O lines are numbered from zero, and correspond one-to-one with software line numbers.
- If strobes and triggers are disabled, their associated lines become general purpose I/O lines. Enabling strobes and/or triggers changes their associated lines from general purpose I/O lines to strobe and trigger lines.

## Parallel I/O Circuit Logic

Figure 25 shows the bidirectional parallel I/O (TTL\_BI) circuit.

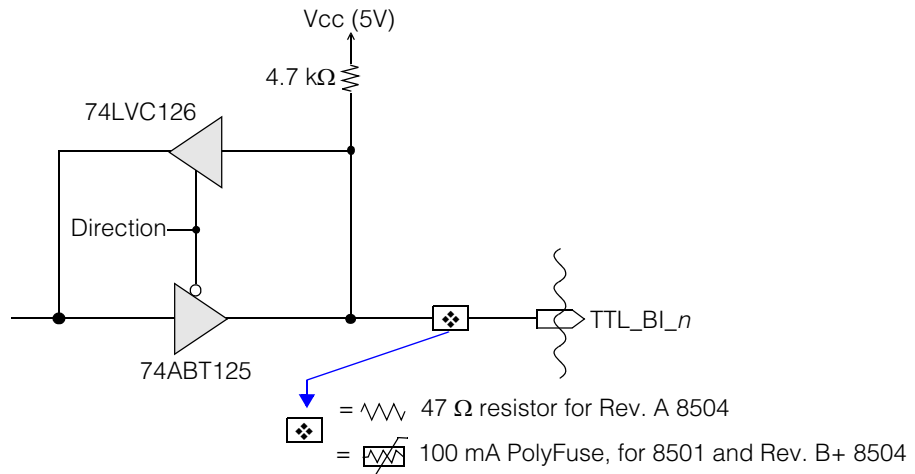

Figure 25. Bidirectional parallel I/O circuit

## Notes on Parallel I/O Circuitry

The special use of some of the sixteen lines as hardware trigger or strobe lines is not enabled at power-on. To use a line's dedicated function as hardware trigger or strobe line, that function must be enabled per line with software commands.

At power-on, all sixteen bidirectional lines are configured as input lines. For any single line, output functionality must be enabled with software commands.

At power-on, all lines are pulled high by an internal pull-up resistor. By contrast, on other Cognex frame grabbers, parallel I/O lines are pulled low or allowed to float.

Keep in mind the following points about the MVS-8500 series parallel I/O circuitry when connecting I/O devices:

- The minimum allowable  $V_{cc}$  is 4.75 V.
- If *direction* is high, the circuit is an input; if *direction* is low, an output.
- In output mode, the 74ABT125 drives the TTL\_BI\_n signal high and low. That is, it is not an open-collector output.

## When Configuring As Outputs

When a bidirectional line is configured as an output line, including lines configured as strobe outputs:

- When driving TTL high ( $V_{OH}$  minimum = 2.0 V), the maximum current drive is 25 mA ( $I_{OH}$  = -25 mA).
- When driving TTL low ( $V_{OL}$  minimum = 0.8 V), the maximum current drive is 32 mA ( $I_{OL}$  = 32 mA).

## When Configuring As Inputs

The following notes apply when using any MVS-8500 series frame grabber's bidirectional parallel I/O lines configured as input lines, including lines configured as trigger inputs:

- Signals must be stable for at least 280 ns to insure that the signal's transition causes an interrupt. If you are using the external opto-isolated module, take into account the small delay added as described in *Opto-Isolated I/O Module Adds Conversion Delay*.
- When connecting a TTL signal to an input line, always drive the line high or low, either to 5 V or to 0 V. Do not leave the line unconnected. For example, do not use a switch that provides the high TTL signal on one side and disconnects the line on the other.
- When connecting an opto-isolated signal to an input line, the opto-isolation circuitry must prevent the line from being disconnected.
- Unused lines can remain disconnected.

# TTL I/O Connection Module

The TTL I/O connection module, part number 800-5818-1, connects to the MDR20 I/O port of the MVS-8500 series frame grabber using Cognex cable 300-0390. The I/O module serves as a pass-through connection point for TTL I/O signal lines originating on the frame grabber. The I/O connection module does not process the signals in any way, and does not require power.

## Cable from MVS-8500 Series to TTL I/O Module

Cognex cable 300-0390 connects an MVS-8500 series frame grabber to a TTL I/O connection module. The MDR20 connector connects to the frame grabber; the DB-25M connects to the I/O module. Figure 26 depicts the cable.

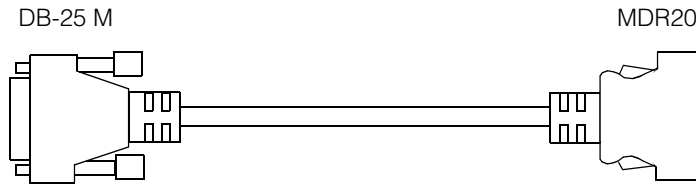

Figure 26. Cable 300-0390

When using cable 300-0390, connect your parallel I/O devices to the TTL I/O module, not to the cable. See diagram of the TTL I/O module in Figure 27 on page 80.

Table 22 shows the pinout of cable 300-0390.

| Pin on DB-25M | Pin on MDR20 | Signal Name at power-on | Signal on MVS-8504, MVS-8514, MVS-8504e, and MVS-8514e, if enabled in software | Signal on MVS-8501, MVS-8511, MVS-8500Le, and MVS-8511e, if enabled in software |
|---------------|--------------|-------------------------|--|---|
| 1             | 7            | TTL_BI_8                | TRIG1  | TRIG  |
| 2             | 17           | TTL_BI_9                | STROBE1  | STROBE  |
| 3             | 8            | TTL_BI_10               | TRIG2  |   |
| 4             | 18           | TTL_BI_11               | STROBE2  |   |
| 5             | 9            | TTL_BI_12               | TRIG3  |   |
| 6             | 19           | TTL_BI_13               | STROBE3  |   |

Table 22. Pinout of cable 300-0390 (      = Not present on MVS-8500Le)

| Pin on DB-25M | Pin on MDR20 | Signal Name at power-on | Signal on MVS-8504, MVS-8514, MVS-8504e, and MVS-8514e, if enabled in software | Signal on MVS-8501, MVS-8511, MVS-8500Le, and MVS-8511e, if enabled in software |
|---------------|--------------|-------------------------|--|---|
| 7             | 10           | TTL_BI_14               | TRIG4  |   |
| 8             | 20           | TTL_BI_15               | STROBE4  |   |
| 9             | 6            | GND                     |  |   |
| 10            | NC           | NC                      |  |   |
| 11            | NC           | NC                      |  |   |
| 12            | NC           | NC                      |  |   |
| 13            | NC           | NC                      |  |   |
| 14            | 2            | TTL_BI_0                |  |   |
| 15            | 12           | TTL_BI_1                |  |   |
| 16            | 3            | TTL_BI_2                |  |   |
| 17            | 13           | TTL_BI_3                |  |   |
| 18            | 4            | TTL_BI_4                |  |   |
| 19            | 14           | TTL_BI_5                |  |   |
| 20            | 5            | TTL_BI_6                |  |   |
| 21            | 15           | TTL_BI_7                |  |   |
| 22            | 16           | GND                     |  |   |
| 23            | NC           | NC                      |  |   |
| 24            | NC           | NC                      |  |   |
| 25            | NC           | NC                      |  |   |

Table 22. Pinout of cable 300-0390 (  = Not present on MVS-8500Le)

## Layout of TTL I/O Connection Module

Figure 27 shows the layout of the TTL I/O connection module, part number 800-5818-1.

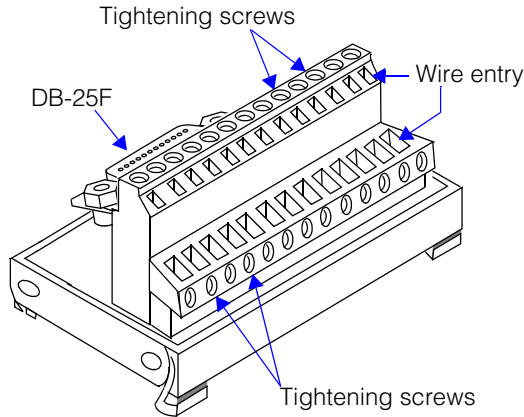

Figure 27. TTL I/O connection module

## Specifications of TTL I/O Connection Module

The following table lists the mechanical and electrical specifications for the external TTL I/O connection module:

| Specification         | Description   |
|-----------------------|---|
| Dimensions            | 3.5 in (width) X 1.75 in (depth) X 2.25 in (height)<br>8.9 cm (width) X 4.4 cm (depth) X 5.7 cm (height)                    |
| Mounting              | DIN 3 rail mountable  |
| Field Wiring Size     | 26 to 12 AWG  |
| Terminal Block Torque | Maximum 0.8 (7) N-M (in-lbf)  |
| Environmental         | Operating Temperature: 0 to 50° C<br>Storage Temperature: -20 to 85° C<br>Relative Humidity: 5 to 95 percent non-condensing |

Table 23. TTL I/O connection module specifications



## TTL I/O Connection Module Terminals

Figure 36 shows the pin numbering for the TTL I/O connection module.

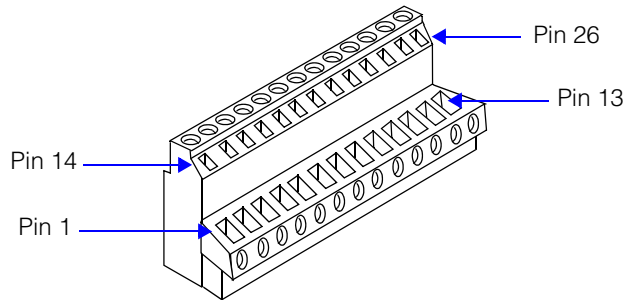

Figure 28. Pin numbering for TTL I/O connection module

Table 24 lists the pinout for the TTL I/O connection module.

| Pin | Signal Name with the MVS-8504, MVS-8514, MVS-8504e, and MVS-8514e | Signal Name with the MVS-8501, MVS-8511, MVS-8500Le, and MVS-8511e | Label |
|-----|---|--|-------|
| 1   | TTL_BI_8 or TRIG1   | TTL_BI_8 or TRIG   | T1    |
| 2   | TTL_BI_9 or STROBE1   | TTL_BI_9 or STROBE   | S1    |
| 3   | TTL_BI_10 or TRIG2  | TTL_BI_10  | T2    |
| 4   | TTL_BI_11 or STROBE2  | TTL_BI_11  | S2    |
| 5   | TTL_BI_12 or TRIG3  | TTL_BI_12  | T3    |
| 6   | TTL_BI_13 or STROBE3  | TTL_BI_13  | S3    |
| 7   | TTL_BI_14 or TRIG4  | TTL_BI_14  | T4    |
| 8   | TTL_BI_15 or STROBE4  | TTL_BI_15  | S4    |
| 9   | GND   | GND  | G     |
| 10  | NC  | NC   | NC    |
| 11  | NC  | NC   | NC    |
| 12  | NC  | NC   | NC    |

Table 24. Pinout of TTL I/O connection module (■ = Not present on MVS-8500Le)

| Pin | Signal Name with the MVS-8504, MVS-8514, MVS-8504e, and MVS-8514e | Signal Name with the MVS-8501, MVS-8511, MVS-8500Le, and MVS-8511e | Label |
|-----|---|--|-------|
| 13  | NC  | NC   | NC    |
| 14  | TTL_BI_0  | TTL_BI_0   | B0    |
| 15  | TTL_BI_1  | TTL_BI_1   | B1    |
| 16  | TTL_BI_2  | TTL_BI_2   | B2    |
| 17  | TTL_BI_3  | TTL_BI_3   | B3    |
| 18  | TTL_BI_4  | TTL_BI_4   | B4    |
| 19  | TTL_BI_5  | TTL_BI_5   | B5    |
| 20  | TTL_BI_6  | TTL_BI_6   | B6    |
| 21  | TTL_BI_7  | TTL_BI_7   | B7    |
| 22  | GND   | GND  | G     |
| 23  | NC  | NC   | NC    |
| 24  | NC  | NC   | NC    |
| 25  | NC  | NC   | NC    |
| 26  | NC  | NC   | NC    |

Table 24. Pinout of TTL I/O connection module (  = Not present on MVS-8500Le)

## Opto-Isolated I/O Connection Module

The external opto-isolated I/O module, part number 800-5712-3, connects to the MDR20 I/O port of the MVS-8500 series using Cognex cable 300-0389 or 300-0399. The I/O module serves as an opto-isolated connection point for parallel I/O signal lines originating on the frame grabber.

Capabilities of the opto-isolated I/O module when used with the MVS-8500 series include:

- Eight optically isolated input lines (four on the MVS-8500Le)
- Eight optically isolated output lines (four on the MVS-8500Le)
- Signal voltage, 5 V to 24 V DC at up to 24 mA
- LEDs to indicate the state of each line
- Powered from the MVS-8500 series
- DIN standard rail mounting

### Note

At power-on, the MVS-8500 series configures all sixteen parallel I/O lines by default as input lines. Even when being used with the opto-isolated I/O module, the eight lines that the module presents as output lines must be configured with software commands as output lines.

## Full Opto Cable from MVS-8500 Series to Opto I/O Module

Cognex cable 300-0389 connects an MVS-8500 series to the opto-isolated I/O module. The MDR20 connector connects to the frame grabber; the DB-26M connects to the I/O module. Figure 29 depicts the cable.

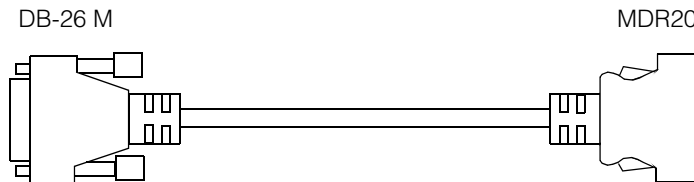

Figure 29. Cable 300-0389

When using cable 300-0389, connect your parallel I/O devices to the opto-isolated I/O module, not to the cable. See diagram of the opto-isolated I/O module in Figure 32 on page 88.

Table 25 shows the pinout of cable 300-0389.

| Pin on DB-26M | Pin on MDR20 | Signal Name with the MVS-8504, MVS-8514, MVS-8504e, and MVS-8514e | Signal Name with the MVS-8501, MVS-8511, MVS-8500Le, and MVS-8511e |
|---------------|--------------|---|--|
| 1             | 2            | TTL_BI_0  | TTL_BI_0   |
| 2             | 12           | TTL_BI_1  | TTL_BI_1   |
| 3             | 3            | TTL_BI_2  | TTL_BI_2   |
| 4             | 13           | TTL_BI_3  | TTL_BI_3   |
| 5             | 7            | TTL_BI_8 or TRIG1   | TTL_BI_8 or TRIG   |
| 6             | 8            | TTL_BI_10 or TRIG2  | TTL_BI_10  |
| 7             | 9            | TTL_BI_12 or TRIG3  | TTL_BI_12  |
| 8             | 10           | TTL_BI_14 or TRIG4  | TTL_BI_14  |
| 9             | 4            | TTL_BI_4  | TTL_BI_4   |
| 10            | 14           | TTL_BI_5  | TTL_BI_5   |
| 11            | 5            | TTL_BI_6  | TTL_BI_6   |
| 12            | 15           | TTL_BI_7  | TTL_BI_7   |
| 13            | 17           | TTL_BI_9 or STROBE1   | TTL_BI_9 or STROBE   |
| 14            | 18           | TTL_BI_11 or STROBE2  | TTL_BI_11  |
| 15            | 19           | TTL_BI_13 or STROBE3  | TTL_BI_13  |
| 16            | 20           | TTL_BI_15 or STROBE4  | TTL_BI_15  |
| 17            | 1            | +5 VDC  | +5 VDC   |
| 18            | 11           | +5 VDC  | +5 VDC   |
| 19            | 6            | GND   | GND  |
| 20            | 16           | GND   | GND  |
| 21-26         | n/a          | —   | —  |

Table 25. Pinout of cable 300-0389 (  = Not present on MVS-8500Le)

## Half Opto Cable from MVS-8500 Series to Opto I/O Module

Cognex cable 300-0399 connects eight of the MVS-8500 series I/O lines to the opto-isolated I/O module, and brings the other eight lines out to a Phoenix 10-pin terminal strip. The MDR20 connector connects to the frame grabber; the DB-26M connects to the opto-isolated I/O module. Figure 30 depicts the cable.

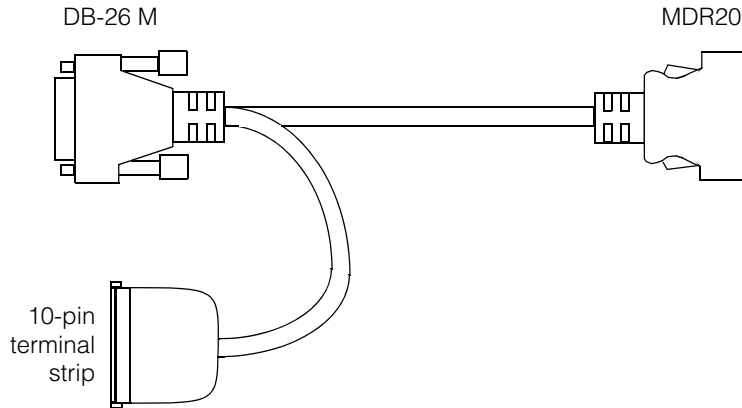

Figure 30. Cable 300-0399

This cable allows you to connect trigger lines directly, without incurring the small delay added by opto-isolation, but at the same time, to take advantage of opto-isolation for strobe lines. This cable provides:

- Four general use opto-isolated input lines
- Four opto-isolated output lines that can be configured as strobe lines
- Four bidirectional TTL lines that can be configured as trigger lines
- Four general use bidirectional TTL lines

Table 26 shows the pinout of cable 300-0399.

| MDR20 pin | Signal name at power-on | Signal, if enabled             |                                 | DB-26M pin | Terminal strip pin |
|-----------|-------------------------|--------------------------------|---------------------------------|------------|--------------------|
|           |                         | MVS-8504, 8514, 8504e, & 8514e | MVS-8501, 8511, 8500Le, & 8511e |            |                    |
| 2         | TTL_BI_0                |                                |                                 | 1          |                    |
| 12        | TTL_BI_1                |                                |                                 | 2          |                    |
| 3         | TTL_BI_2                |                                |                                 | 3          |                    |
| 13        | TTL_BI_3                |                                |                                 | 4          |                    |
| 17        | TTL_BI_9                | STROBE1                        | STROBE                          | 13         |                    |
| 18        | TTL_BI_11               | STROBE2                        |                                 | 14         |                    |
| 19        | TTL_BI_13               | STROBE3                        |                                 | 15         |                    |
| 20        | TTL_BI_15               | STROBE4                        |                                 | 16         |                    |
| 1         | +5 VDC                  |                                |                                 | 17         |                    |
| 11        | +5 VDC                  |                                |                                 | 18         |                    |
| 16        | GND                     |                                |                                 | 19         |                    |
| 7         | TTL_BI_8                | TRIG1                          | TRIG                            |            | 1                  |
| 8         | TTL_BI_10               | TRIG2                          |                                 |            | 2                  |
| 9         | TTL_BI_12               | TRIG3                          |                                 |            | 3                  |
| 10        | TTL_BI_14               | TRIG4                          |                                 |            | 4                  |
| 4         | TTL_BI_4                |                                |                                 |            | 5                  |
| 14        | TTL_BI_5                |                                |                                 |            | 6                  |
| 5         | TTL_BI_6                |                                |                                 |            | 7                  |
| 15        | TTL_BI_7                |                                |                                 |            | 8                  |
| 6         | GND                     |                                |                                 |            | 9                  |

Table 26. Pinout of cable 300-0399 (  = Not present on MVS-8500Le)

The terminal strip branch of cable 300-0399 has a 10-position Phoenix connector, with male screw terminal strip attached. Connect wires from your parallel I/O devices to the screw terminal strip. Figure 31 shows the pin numbering of the terminal strip.

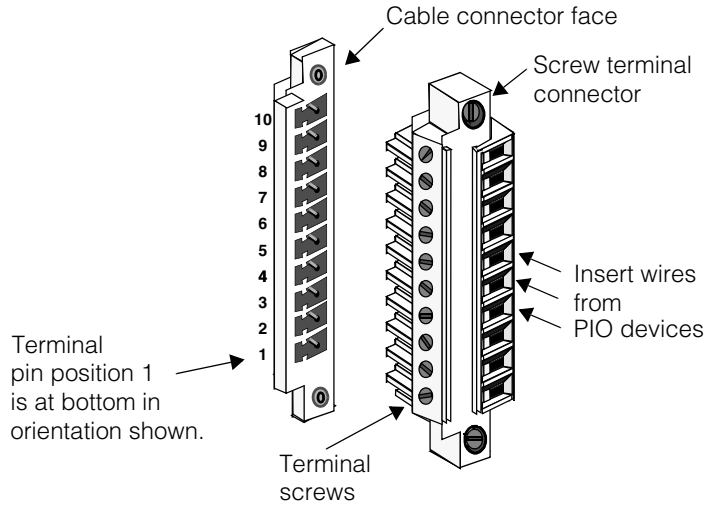
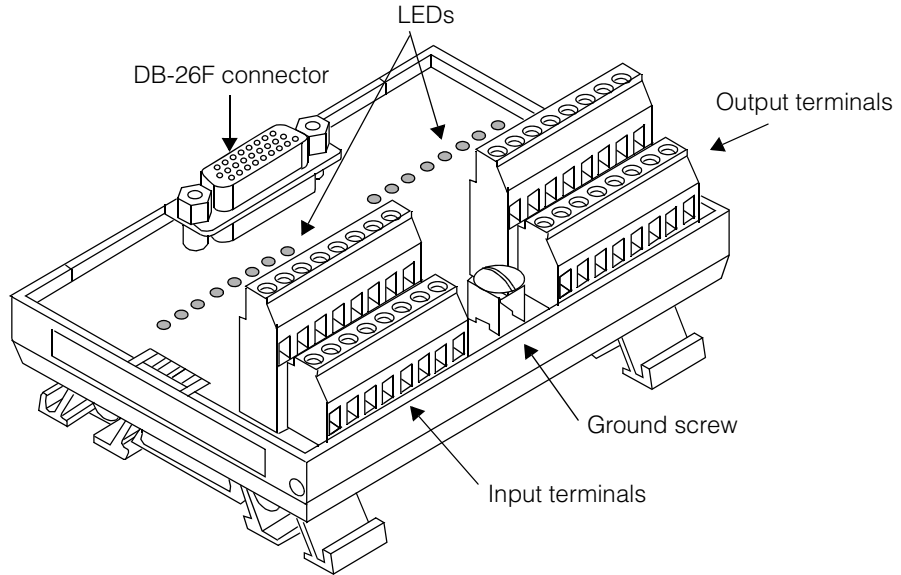

*Figure 31. Screw terminal end of cable 300-0399*

For the pinout of the opto-isolated I/O module when used with cable 300-0399, see Table 29 on page 95 and Table 31 on page 97.

## Layout of Opto-Isolated I/O Connection Module

Figure 32 shows the layout and major components of the opto-isolated I/O module.



*Figure 32. Parts layout of opto-isolated I/O module*

The DB-26F connector provides a connection from the MVS-8500 series through either the full opto or half opto cables.

The input and output screw terminals provide connection points for connecting wires from parallel I/O devices.

The LEDs indicate the availability of power to the input and output lines.



## Specifications of Opto-Isolated I/O Module

The following table lists the mechanical and electrical specifications for the opto-isolated I/O module:

| Specification                     | Description   |
|-----------------------------------|---|
| Dimensions                        | 4.75 in (width) X 3.25 in (depth) X 2.31 in (height)<br>1.2 cm (width) X 8.3 cm (depth) X 5.8 cm (height)                   |
| Mounting                          | DIN 3 rail mountable  |
| Operating Voltage<br>(Field Side) | 5 V to 24 V DC  |
| Power                             | +5 V DC, supplied from the MVS-8500 series frame grabber  |
| Maximum Output Current            | 24 mA (sink or source)  |
| ON State Voltage Drop             | 0.8 V DC @ 10 mA, 2.6 V DC @ 24 mA  |
| OFF State Leakage Current         | 100 $\mu$ A maximum @ 15 V DC   |
| Output Delay                      | ON: 6 $\mu$ Sec<br>OFF: 130 $\mu$ Sec @ 5 mA<br>95 $\mu$ Sec @ 10 mA;<br>85 $\mu$ Sec @ 15 mA                               |
| Input Resistance                  | ~1000 Ohms  |
| Input State Current               | ON: 3.5 to 24 mA<br>OFF: 500 $\mu$ A  |
| Input Delay                       | ON: 30 $\mu$ Sec @ 3.5 mA; 8 $\mu$ Sec @ 15 mA<br>OFF: 45 $\mu$ Sec @ 3.5 mA; 80 $\mu$ Sec @ 15 mA                          |
| Field Wiring Size                 | 26 to 12 AWG  |
| Terminal Block Torque             | Maximum 0.8 (7) N-M (in-lbf)  |
| Environmental                     | Operating Temperature: 0 to 50° C<br>Storage Temperature: -20 to 85° C<br>Relative Humidity: 5 to 95 percent non-condensing |

Table 27. Opto-isolated I/O module specifications

## Opto-Isolated I/O Module LED Numbering

The opto-isolated I/O module has silk-screened labels identifying the LEDs for each input and output plus/minus connection pair. The labels identify the connection points using zero-based numbers, IN 0 through IN 7, and OUT 0 through OUT 7.

To map these labels to the signal lines coming from the MVS-8500 series frame grabber, see *Opto-Isolated I/O Module Input Terminals* on page 93 and *Opto-Isolated I/O Module Output Terminals* on page 96.

## Opto-Isolated I/O Module Adds Conversion Delay

The opto-isolated I/O module converts all digital TTL signals from the MVS-8500 series into opto-isolated signal pairs. The opto-isolation circuitry of the I/O module adds a delay of 100 to 300 microseconds, compared to a pure TTL signal. For comparison, the response time of a typical TTL signal is about 1 microsecond.

An output device will receive its signal 100 to 300 microseconds slower when connected to the opto-isolated I/O module than when connected to the TTL I/O module.

A signal from an input device will be delayed from reaching the MVS-8500 series by 100 to 300 microseconds, compared to the same device going through the TTL I/O module.

A delay of this small magnitude is not visible to the naked eye, but may have a cumulative effect when multiplied over many rapid image acquisitions. Take this delay into account when calculating your maximum image processing throughput if you plan to use the opto-isolated I/O module.

## Opto-Isolated I/O Module Wiring Methods

Figure 33 shows the methods for connecting input and output signal lines to the respective terminal plugs of the opto-isolated I/O module.

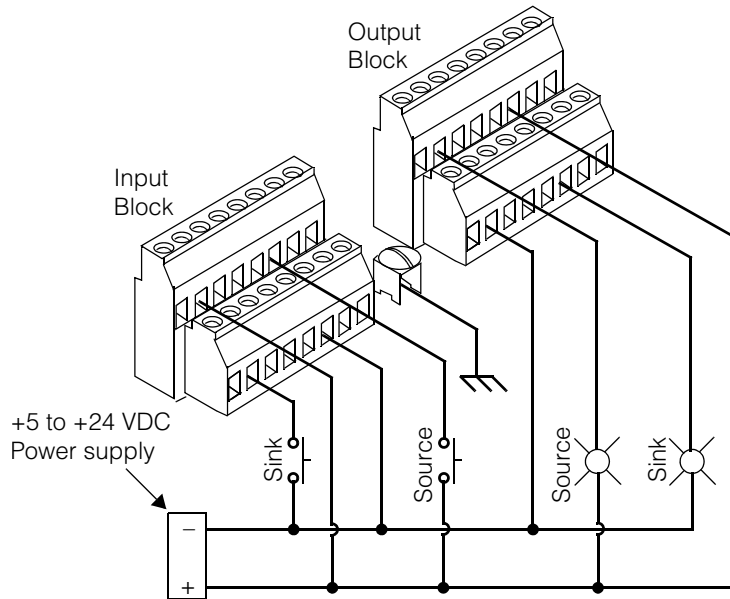

Figure 33. Wiring methods for connecting to the external I/O module

For both input and output signal lines, connect the source side of the signal to a positive-numbered terminal and the sink side to a negative-numbered terminal.

## Opto-Isolated I/O Module Circuit Logic

Figure 34 shows a typical input schematic to help you determine how to wire your input devices to the opto-isolated I/O module.

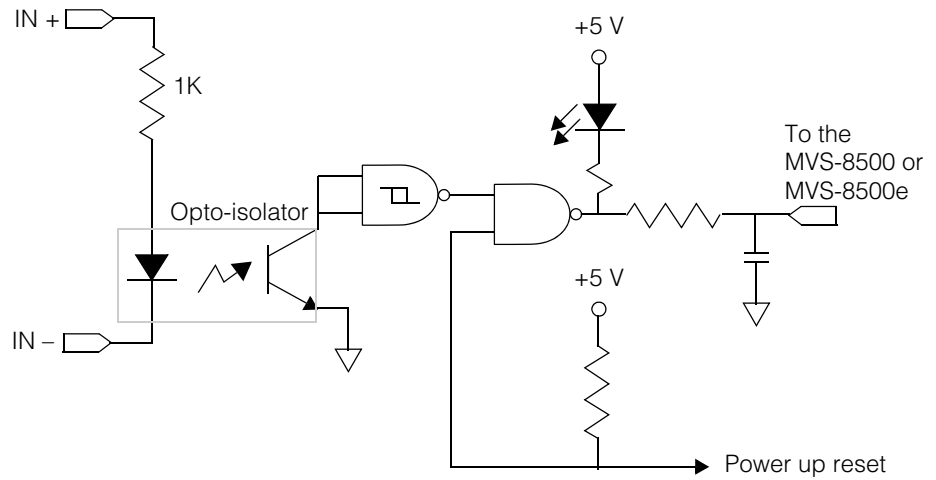

Figure 34. Typical input schematic for opto-isolated I/O module

The following figure shows a typical output schematic to help you determine how to wire your output devices to the opto-isolated I/O module.

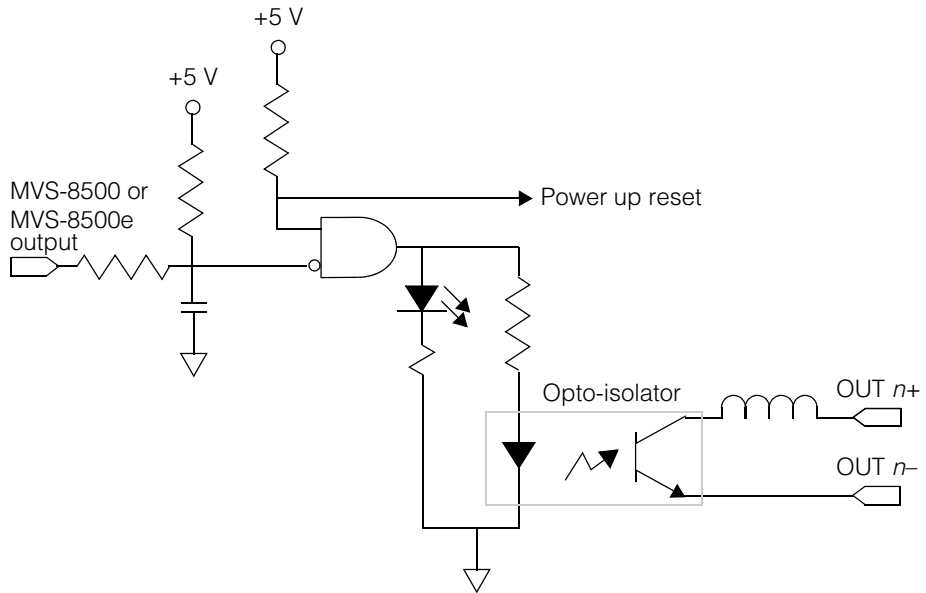

Figure 35. Typical output schematic for external I/O module

## Opto-Isolated I/O Module Input Terminals

Figure 36 shows the pin numbering for the input terminal block of the opto-isolated I/O module.

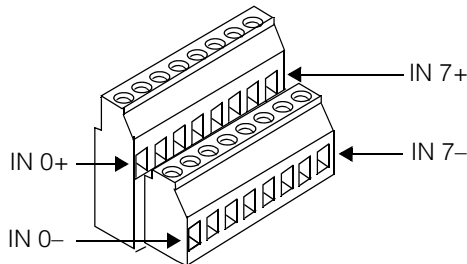

Figure 36. Pin numbering for input terminal block

## Input Block Pinout with Full Opto Cable

Table 28 lists the pinout for the input block of the opto-isolated I/O module when using the all opto option and cable 300-0389.

| Signal from MVS-8500 series | Pin Number | Device Connection when using cable 300-0389 |  |
|-----------------------------|------------|---|--|
|                             |            | With MVS-8504, 8514, 8504e, & 8514e         | With MVS-8501, 8511, 8500Le & 8511e                        |
| TTL_BI_0                    | IN 0+      | Any input device (no longer bidirectional)  | Any input device (no longer bidirectional)                 |
|                             | IN 0-      |   |  |
| TTL_BI_1                    | IN 1+      | Any input device (no longer bidirectional)  | Any input device (no longer bidirectional)                 |
|                             | IN 1-      |   |  |
| TTL_BI_2                    | IN 2+      | Any input device (no longer bidirectional)  | Any input device (no longer bidirectional)                 |
|                             | IN 2-      |   |  |
| TTL_BI_3                    | IN 3+      | Any input device (no longer bidirectional)  | Any input device (no longer bidirectional)                 |
|                             | IN 3-      |   |  |
| TTL_BI_8                    | IN 4+      | Trigger 1 if enabled or any input device    | Trigger for active camera, if enabled, or any input device |
|                             | IN 4-      |   |  |
| TTL_BI_10                   | IN 5+      | Trigger 2 if enabled or any input device    | Any input device (no longer bidirectional)                 |
|                             | IN 5-      |   |  |
| TTL_BI_12                   | IN 6+      | Trigger 3 if enabled or any input device    | Any input device (no longer bidirectional)                 |
|                             | IN 6-      |   |  |
| TTL_BI_14                   | IN 7+      | Trigger 4 if enabled or any input device    | Any input device (no longer bidirectional)                 |
|                             | IN 7-      |   |  |

Table 28. Pinout for input block of opto-isolated I/O module with 300-0389 (  = Not present on MVS-8500Le)

## Input Block Pinout with Half Opto Cable

Table 29 lists the pinout for the input block of the opto-isolated I/O module when using the half opto, half TTL option and cable 300-0399, connecting from the MVS-8500 series, except for the MVS-8500Le (none of the lines described in Table 29 are present on the MVS-8500Le).

| <b>TTL signal from MVS-8500 series (except MVS-8500Le)</b> | <b>Pin Number</b> | <b>Device Connection when using cable 300-0399</b> |
|--|-------------------|--|
| TTL_BI_0   | IN 0+             | Any input device<br>(no longer bidirectional)      |
|  | IN 0-             |  |
| TTL_BI_1   | IN 1+             | Any input device<br>(no longer bidirectional)      |
|  | IN 1-             |  |
| TTL_BI_2   | IN 2+             | Any input device<br>(no longer bidirectional)      |
|  | IN 2-             |  |
| TTL_BI_3   | IN 3+             | Any input device<br>(no longer bidirectional)      |
|  | IN 3-             |  |
|  | IN 4              | No connection                                      |
|  | IN 5              | No connection                                      |
|  | IN 6              | No connection                                      |
|  | IN 7              | No connection                                      |

Table 29. Pinout for input block of opto-isolated I/O module with 300-0399

## Opto-Isolated I/O Module Output Terminals

### Output Block Pinout with Full Opto Cable

Table 30 lists the pinout for the output terminal block of the opto-isolated I/O module when using the all opto option and cable 300-0389.

| Signal from MVS-8500 series | Pin Number | Device connection when using cable 300-0389     |  |
|-----------------------------|------------|---|--|
|                             |            | With MVS-8504, MVS-8514, MVS-8504e, & MVS-8514e | With MVS-8501, MVS-8511, MVS-8500Le, & MVS-8511e               |
| TTL_BI_4                    | OUT 0+     | Any output device (no longer bidirectional)     | Any output device (no longer bidirectional)                    |
|                             | OUT 0-     |   |  |
| TTL_BI_5                    | OUT 1+     | Any output device (no longer bidirectional)     | Any output device (no longer bidirectional)                    |
|                             | OUT 1-     |   |  |
| TTL_BI_6                    | OUT 2+     | Any output device (no longer bidirectional)     | Any output device (no longer bidirectional)                    |
|                             | OUT 2-     |   |  |
| TTL_BI_7                    | OUT 3+     | Any output device (no longer bidirectional)     | Any output device (no longer bidirectional)                    |
|                             | OUT 3-     |   |  |
| TTL_BI_9                    | OUT 4+     | Strobe 1 if enabled or any output device        | Strobe for the active camera, if enabled, or any output device |
|                             | OUT 4-     |   |  |
| TTL_BI_11                   | OUT 5+     | Strobe 2 if enabled or any output device        | Any output device (no longer bidirectional)                    |
|                             | OUT 5-     |   |  |
| TTL_BI_13                   | OUT 6+     | Strobe 3 if enabled or any output device        | Any output device (no longer bidirectional)                    |
|                             | OUT 6-     |   |  |
| TTL_BI_15                   | OUT 7+     | Strobe 4 if enabled or any output device        | Any output device (no longer bidirectional)                    |
|                             | OUT 7-     |   |  |

Table 30. Pinout for output block of opto-isolated I/O module with 300-0389 (  = Not present on MVS-8500Le)



## Output Block Pinout with Half Opto Cable

Table 31 lists the pinout for the output terminal block of the opto-isolated I/O module when using the half opto, half TTL option and cable 300-0399.

| Signal from frame grabber | Pin Number | Device connection when using cable 300-0399     |  |
|---------------------------|------------|---|--|
|                           |            | With MVS-8504, MVS-8514, MVS-8504e, & MVS-8514e | With MVS-8501, MVS-8511, MVS-8500Le, & MVS-8511e           |
|                           | OUT 0      | No connection                                   |  |
|                           | OUT 1      | No connection                                   |  |
|                           | OUT 2      | No connection                                   |  |
|                           | OUT 3      | No connection                                   |  |
| TTL_BI_9                  | OUT 4+     | Strobe 1 if enabled or any output device        | Strobe for active camera, if enabled, or any output device |
|                           | OUT 4-     |   |  |
| TTL_BI_11                 | OUT 5+     | Strobe 2 if enabled or any output device        | Any output device (no longer bidirectional)                |
|                           | OUT 5-     |   |  |
| TTL_BI_13                 | OUT 6+     | Strobe 3 if enabled or any output device        | Any output device (no longer bidirectional)                |
|                           | OUT 6-     |   |  |
| TTL_BI_15                 | OUT 7+     | Strobe 4 if enabled or any output device        | Any output device (no longer bidirectional)                |
|                           | OUT 7-     |   |  |

Table 31. Pinout for output block of opto-isolated I/O module with 300-0399

Figure 37 shows the pin numbering for the output terminal block of the opto-isolated I/O module.

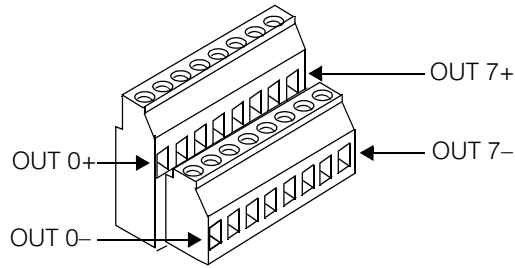

Figure 37. Pin numbering for output terminal block

## Hirose HR10 Connector Description

The Hirose HR10 12-pin connector is used in many industrial camera and frame grabber products.

The HR10 connector series has a push-pull locking mechanism and gold-plated contacts. The HR10A series is the same except for silver-plated contacts and an optional threaded coupling as an alternative to push-pull locking.

Hirose HR10 part numbers are interpreted as follows:

HR10-10x-12y

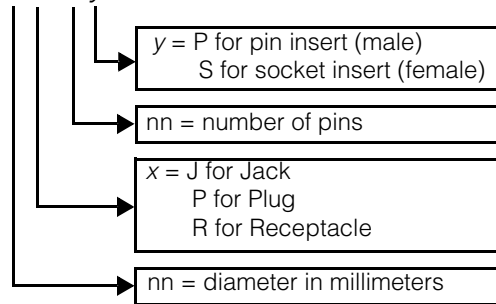

In the Hirose HR10 series, plugs mate into either jacks or receptacles.

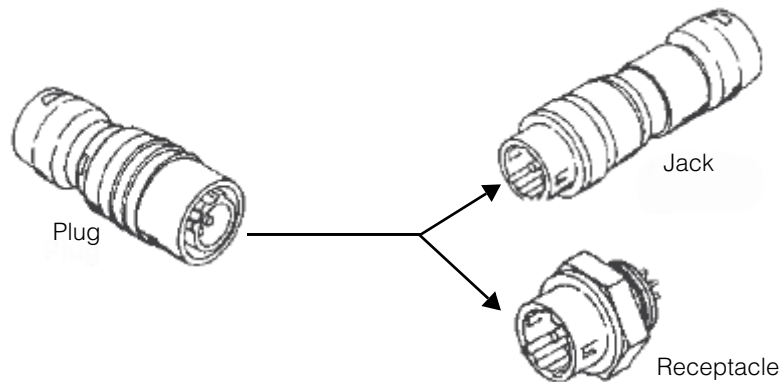

Table 32 differentiates plugs, jacks, and receptacles.

| Characteristic                       | Plug | Jack | Receptacle |
|--------------------------------------|------|------|------------|
| Has outer hood around pin cylinder   | yes  | no   | no         |
| May have pin insert (male pins)      | yes  | yes  | yes        |
| May have socket insert (female pins) | yes  | yes  | yes        |
| Cable-mounted                        | yes  | yes  | no         |
| Panel-mounted                        | no   | no   | yes        |

Table 32. HR10 Plugs, Jacks, and Receptacles

**Note** Plugs, jacks, and receptacles can ALL be either male or female.

## Pin Numbering of HR10 Jacks and Plugs

Figure 38 shows the pin numbering for the HR10-10J-12S jacks on the 300-0230, 300-0232, and 300-9116 monochrome and 300-0406 monochrome/color breakout cables. These jacks are used to connect to monochrome cameras.

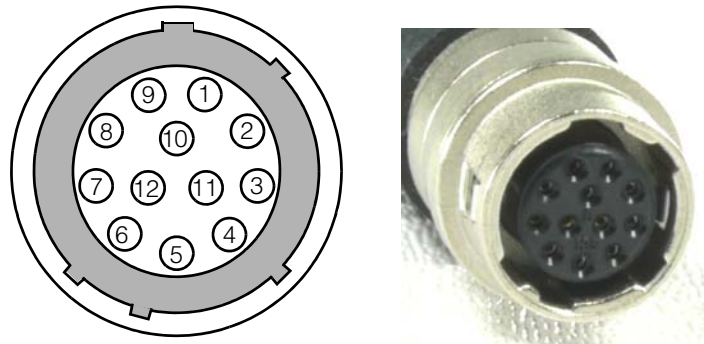
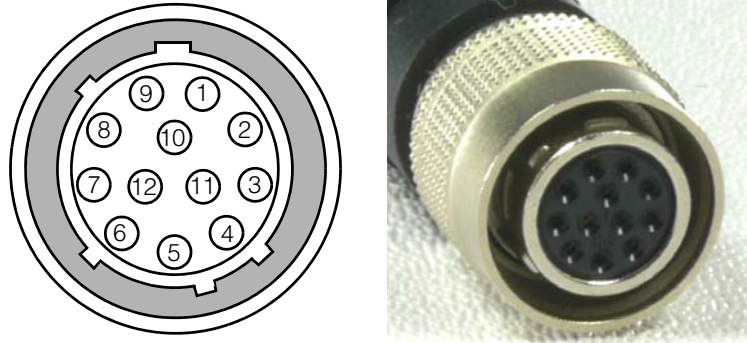

Figure 38. Hirose HR10-10J-12S jack pin numbering

Figure 39 shows the pin numbering for HR10-10P-12S plug on the 300-0406 monochrome/color breakout cable. This plug is used to connect the DC IN/VBS OUT connector on the Sony DXC-390 color camera.



*Figure 39. Hirose HR10-10P-12S plug pin numbering*



# Index

## Numerics

300-0175 24  
300-0176 32  
300-0230 66, 67, 68  
300-0232 66, 67  
300-0389 41, 43, 53, 73, 83, 84, 94, 96, 97  
300-0390 41, 42, 53, 73, 78  
300-0391 24, 57  
300-0399 41, 45, 53, 73, 85, 86, 87, 95, 97  
300-0406 32, 66, 69, 70  
    camera software addresses for 70  
66 MHz PCI 21  
800-5712-3 41, 43, 73, 83  
800-5818-1 41, 73, 78, 80

## A

address  
    camera, with cable 300-0406 70  
AMD Athlon 20

## B

bidirectional TTL 43  
    circuit diagram 76  
    no longer bidirectional 44, 45  
breakout cable  
    choosing between mono cables 69  
    color+monochrome 66, 69, 70  
    mono with power input 66, 67, 68  
    mono, cameras only 66, 67

## C

cable  
    full opto 83  
    half opto 85  
    to TTL I/O module 78  
camera  
    addresses for cable 300-0406 70  
    JAI CV-A1 27, 28  
    Sony DXC-390 30, 31, 32, 40, 70  
    Sony XC-55 32, 33  
    Sony XC-75 emulation 33  
    Sony XC-ES50 33, 34  
    Sony XC-HR50 35  
    Sony XC-HR57 35  
    Sony XC-HR58 35  
    Sony XC-HR70 35  
    Sony XC-ST50 36  
    Teli CS8541D 37, 38, 40  
    Toshiba IK-53V 38  
camera control tool  
    JAI, for CV-A1 27, 28  
caution  
    electrostatic discharge can  
        damage 23  
    hot plugging not supported 40, 41  
    must use Cognex cables 71  
    no PC power while connecting  
        cameras and devices 26  
    same ground potential with external  
        I/O module 43, 45  
CCT 27, 28  
chip set 20  
circuit diagram  
    bidirectional TTL 76  
    opto-isolated I/O module, inputs 92  
    opto-isolated I/O module, outputs 93  
color camera 30, 50  
component location  
    on MVS-8500 54, 55, 56

connecting  
  opto-isolated devices 43, 44  
  parallel I/O devices 41  
  TTL devices 42

connector  
  DB-25 42  
  DB-26F 63, 67, 69  
  DC IN/SYNC 67  
  DC IN/VBS 31  
  DC IN/VBS OUT 70  
  DIN-5 on breakout cable 67, 68  
  Hirose 40, 66, 67, 70  
  RGB/SYNC 70  
  VIDEO OUT 31

CS8541D 37, 38, 40

CV-A1 27, 28

## D

DB-25 connector 42

DB-26F connector 57, 63, 67, 69

DC IN/SYNC connector 67

DC IN/VBS connector 31

DC IN/VBS OUT connector 70

DXC-390 30, 31, 32, 40, 70

## E

E-DONPISHA 33, 35

electrical specifications 60

electromagnetic  
  compatibility standard 59

electrostatic sensitivity standards 59

emulation  
  of Sony XC-75 33

environmental requirements 58

## F

factory default  
  settings for Sony XC-ES50 34  
  settings for Sony XC-ST50 36

FCC class A 59

full opto cable 83

fuses  
  camera input not fused with cable  
    300-0230 68  
  PolySwitch 62

## H

half opto cable 85

Hirose 40, 66, 67, 70  
  description of HR10 connector 99  
  pin numbering 100, 101

hot plugging  
  not supported 40, 41

humidity 58

## I

IK-53V 38

immediate mode triggering 53

installing  
  opto-isolated devices 43, 44  
  parallel I/O devices 41  
  TTL devices 42

## J

JAI  
  camera control tool 27, 28  
  CV-A1 27, 28



**L**

- LED numbering
  - on opto I/O module 90
- LEDs on circuit board 54, 55
- line numbering
  - bidirectional TTL lines 75
  - trigger and strobe lines 75
  - when using 300-0406 cable 70

**M**

- MDR20 42, 43, 45, 52, 53, 57, 63, 73, 74, 78, 83, 84, 85, 86
- MVS-8500
  - component location 54, 55, 56
- MVS-8501
  - compared to MVS-8504 49, 72
  - power requirements 60
- MVS-8504
  - power requirements 60

**O**

- opto-isolated I/O module 43, 44, 73, 83, 85, 87
  - circuit diagrams 92, 93
  - delay added by 90
  - features 83
  - input block 93, 94, 95
  - layout 88
  - LED numbering 90
  - output block 96, 97, 98
  - overview 83
  - specifications 89
  - wiring methods 91

**P**

- part numbers
  - 300-0175 24
  - 300-0176 32
  - 300-0230 66, 67, 68
  - 300-0232 66, 67
  - 300-0389 41, 43, 53, 73, 83, 84, 94, 96, 97
  - 300-0390 41, 42, 53, 73, 78
  - 300-0391 24, 57
  - 300-0399 41, 45, 53, 73, 85, 86, 87, 95, 97
  - 300-0406 32, 66, 69, 70
  - 800-5712-3 41, 43, 73, 83
  - 800-5818-1 41, 73, 78, 80
- PC
  - requirements 20
- PCI
  - 66 MHz 21
- PCI bus
  - interface 48
- PCI Express bus
  - interface 48
- PCI-X 21, 22, 48
- Pentium 20
- pin numbering
  - breakout cable's power connector 68
  - camera input port 63
  - Hirose connector 100, 101
  - input block on opto-isolated I/O module 93
  - output block on opto-isolated I/O module 98
  - parallel I/O connector 74
  - TTL I/O connection module 81

- pinout
  - breakout cable's power connector 68
  - cable 300-0389 84
  - cable 300-0390 78
  - cable 300-0399 86
  - camera input port 64
  - Hirose connector 70
  - opto I/O module input block with 300-0389 94
  - opto I/O module input block with 300-0399 95
  - opto I/O module output block with 300-0389 96
  - opto I/O module output block with 300-0399 97
  - parallel I/O connector 74
  - TTL I/O connection module 81
- PolySwitch fuse
  - resetting 63
- power requirements
  - MVS-8501 60
  - MVS-8504 60
- progressive scan 35, 38, 48

## R

- requirements
  - environmental 58
  - for host PC 20
- RGB/SYNC connector 70

## S

- S102
  - switch on Sony DXC-390 31
- safety standards 59
- serial cable 27, 28

- Sony
  - DXC-390 30, 31, 32, 40, 70
  - XC-55 32, 33
  - XC-75 emulation 33
  - XC-ES50 33, 34
  - XC-HR50 35
  - XC-HR57 35
  - XC-HR58 35
  - XC-HR70 35
  - XC-ST50 36
- specifications
  - electrical, of MVS-8500 60
  - environmental, inside host PC 58
  - MVS-8500 49
  - opto-isolated I/O module 89
  - TTL I/O connection module 80
- standards
  - electromagnetic compatibility 59
  - electrostatic sensitivity 59
  - safety 59
- strobe 41, 44, 45, 52, 53, 57, 71, 72, 73, 75, 76, 85, 96, 97
- switch
  - S102 31
- switch settings
  - for Sony XC-55 33
  - for Sony XC-HR series 35
  - for Sony XC-ST50 camera family 36
  - for Teli CS8541D 37, 38
  - for Toshiba IK-53V 38

## T

- Teli
  - CS8541D 37, 38, 40
- temperature 58
- Toshiba
  - IK-53V 38

trigger 41, 44, 45, 52, 53, 57, 71, 72, 73,  
75, 76, 85, 94

    immediate mode 53

trigger shutter 33, 35

TTL

    bidirectional 43

    bidirectional, circuit diagram 76

    cable 78

    no longer bidirectional 44, 45

TTL I/O connection module 78, 80, 81  
    specifications 80

## V

VIA 20

VIDEO OUT connector 31

## X

XC-55 32, 33

XC-75 emulation 33

XC-HR50 35

XC-HR57 35

XC-HR58 35

XC-HR70 35

## ■ Index

---